

Light Commercial Air Conditioner R410A ON/OFF

Service Manual

2013



Большая библиотека технической документации

<https://splitsystema48.ru/instrukcii-po-ekspluatácii-kondicionerov.html>

каталоги, инструкции, сервисные мануалы, схемы.

Part 1 General Information	2
Part 2 Indoor Units.....	8
Part 3 Outdoor Units.....	82
Part 4 Installation	106

※ The specifications, designs, and information in this book are subject to change without notice for product improvement.

Part 1

General Information

1. Model Names of Indoor/Outdoor Units.....	3
2. External Appearance	4
2.1 Indoor Units	4
2.2 Outdoor Units	5
3. Nomenclature	6
4. Features	7

1. Model Names of Indoor/Outdoor Units

1.1 Indoor Units

R410A (capacity multiplied by 1000Btu/h)

Type	Function	50	60	100	140	200	250
Four-way cassette (compact)	Cooling and heating	√					
Four-way cassette	Cooling and heating		√	√	√	√	
Ceiling & floor	Cooling and heating	√	√	√	√	√	
High Static Pressure Duct	Cooling and heating		√	√	√	√	√

1.2 Outdoor Units

Model of outdoor unit and corresponding indoor unit

Universal Outdoor unit Model	Compressor Brand	Matched indoor units
Heat Pump		
SOB-50VA	SANYO	SIB-50BAV SIB-50TAV
SOB-60VA	SANYO	SIB-60BAV SIB-60TAV SIB-60DAV
SOB-100YA	SANYO	SIB-100BAY SIB-100TAY SIB-100DAY
SOB-140YA	SANYO	SIB-140BAY SIB-140TAY SIB-140DAY
SOB-200YA	SANYO	SIB-200BAY SIB-200TAY SIB-200DAY
SOB-250YA	SANYO	SIB-250DAY

2. External Appearance

2.1 Indoor Units

Four-way Cassette (Compact)



Four-way Cassette



Ceiling & Floor



High Static Pressure Duct



2.2 Outdoor Units



3. Nomenclature

3.1 Indoor Unit

S I B-60TA V A

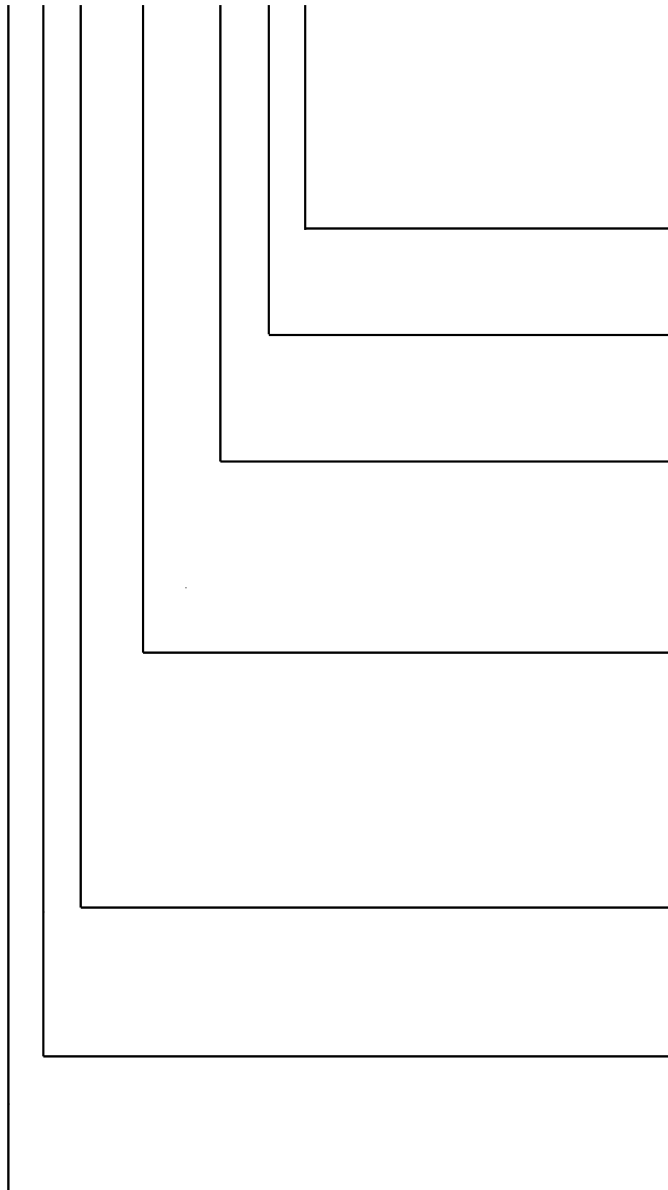

Refrigerant

A - R410A

Power

V - 1 phase, 50 Hz

Y - 3 phases, 50 Hz

Product category

BA – Cassette type

TA – High static pressure duct

DA – Ceiling & Floor type

Capacity

50 – 5,2kWt

60 – 7,0kWt

100 – 10,5kWt

140 – 14,0kWt

200 – 17,6kWt

250 – 28,0Wt

Series

B - Business

Unit

I – Indoor

O – Outdoor

Manufacturer's brand

S(akata)

4. Features

4.1 High quality coils:

The coil is constructed of advanced inner grooved copper tube and aluminum fins.



4.2 Anti-rust, 500 hours salt spray test.

4.3 Low operation sound level: Well-known stable and quiet running fan motor.

4.4 Well-known compressor.

4.5 Compact design: Smaller dimension and larger stuffing capacity.

4.6 Universal outdoor unit design.

4.7 R410A environment friendly refrigerant.

Part 2

Indoor Units

Four-way Cassette Type (Compact).....	9
Four-way Cassette Type.....	21
Ceiling & Floor Type	41
HSP Duct Type	63

Four-way Cassette Type (Compact)

1. Features	10
2. Specifications.....	11
3. Dimensions.....	12
4. Service Space.....	13
5. Capacity tables.....	14
6. Wiring Diagrams	15
7. Air Velocity and Temperature Distributions	16
8. Electric Characteristics.....	17
9. Sound Levels.....	18
10. The Specification of Power.....	19
11. Field Wiring.....	20

1. Features

- (1) Low operation noise
 - Streamline plate ensures quietness
 - Creates natural and comfortable environment
- (2) Efficient cooling
 - Equal, fast and wide—range cooling
- (3) The adoption of the most advanced 3- Dimensional Screw fan
 - Reduces the air resistance passing through
 - Smooths the air flow
 - Makes air speed distribution to the heat exchange uniform

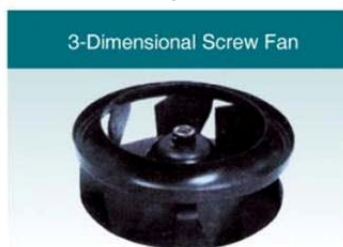

- (4) Improvement for easy installation and maintenance
 - Little space is required for installation into a shallow ceiling
 - Because of the compactness and weight reduction of the main unit and panel, all models can be installed without a hoist

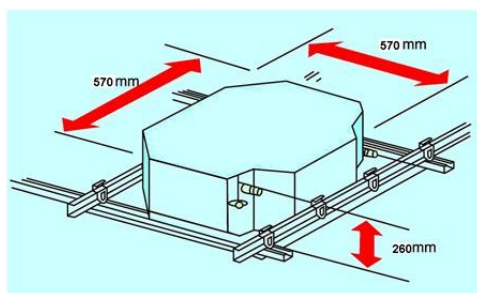

- (5) Inside E-box design

The E-box is simply and safely build inside the indoor unit, of witch ceiling side is 600mm*600mm. It is convenient to install and maintain. Checking the control part is easy, you only need to open the air return grille.

2. Specifications

Model		SIB-50BAV	
Power supply		V-ph-Hz	220~240-1-50
Cooling	Capacity	Btu/h	18000
		kW	5.28
	Input	W	1834
	EER		2.89
Heating	Capacity	Btu/h	20000
		kW	5.86
	Input	W	1881
	COP		3,19
Indoor fan motor	Model		YDK37-4P
	Qty		1
	Input	W	80/65/46
	Capacitor	uF	2UF/400-450V
	Speed(Hi/Mi/Lo)	r/min	1000/875/710
Indoor coil	Number of rows		2
	Tube pitch(a)×row pitch(b)	mm	21×13.37
	Fin spacing	mm	1.3
	Fin type (code)		Hydrophilic aluminum
	Tube outside dia. and type	mm	∅7Inner grooved copper tube
	Coil length × height × width	mm	1370×210×26.74
	Number of circuits		4
Indoor air flow (Hi/Mi/Lo)		m ³ /h	860/760/500
Indoor noise level (sound pressure)		dB(A)	44/41/38
Indoor unit	Dimension (W×H×D)(body)	mm	570×260×570
	Packing (W×H×D)(body)	mm	655×290×655
	Dimension (W×H×D)(panel)	mm	647×50×647
	Packing (W×H×D)(panel)	mm	705×113×705
	Net/Gross weight(body)	kg	19/21
	Net/Gross weight(panel)	kg	2.5/4.5
Refrigerant type			R410A
Design pressure		MPa	4.2/1.5
Refrigerant piping	Liquid side/ Gas side	mm	∅6.4/∅12.7
Drainage water pipe diameter		mm	OD∅25
Controller			RG36C/BG(C)E
Operation temperature		°C	17-30

- Notes:**
- Nominal cooling capacities are based on the following conditions:
Indoor temp: 27°CDB, 19°CWB; Outdoor temp: 35°CDB; Equivalent ref. Piping: 7.5m(horizontal)
 - Nominal heating capacities are based on the following conditions:
Indoor temp: 20°CDB; Outdoor temp: 7°CDB, 6°CWB; Equivalent ref. Piping: 7.5m(horizontal)
 - Actual noise level may differ, depending on the room structure, etc, since these noise values are from an anechoic room.

3. Dimensions

SIB-50BAV

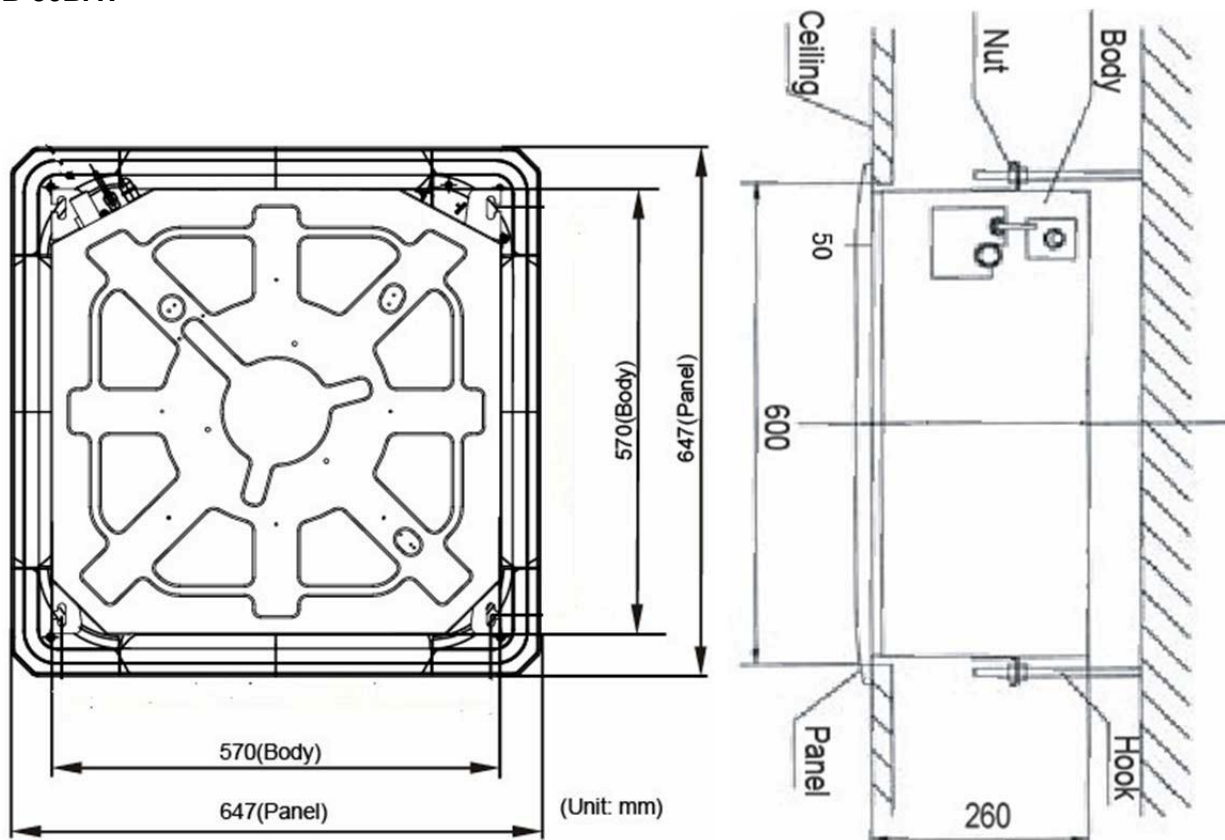

4. Service Space

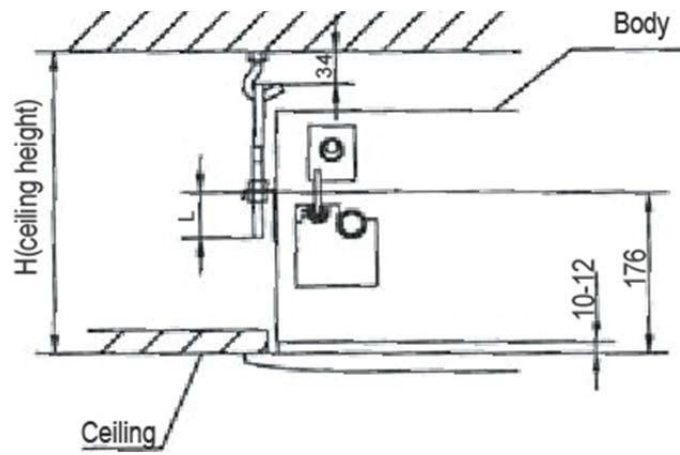
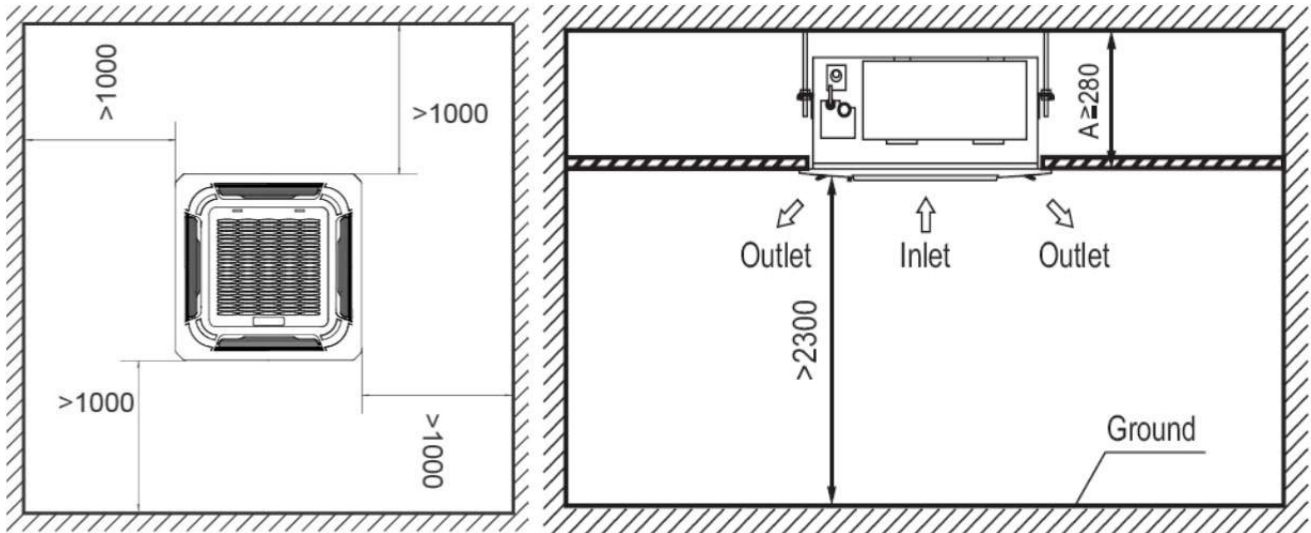

5. Capacity tables

5.1 SIB-50BAV

Cooling		OUTDOOR TEMPERATURE DRY					
Indoor Conditions		21°C	25°C	30°C	35°C	40°C	45°C
21°C D 15°C W	Total capacity kW	4.91	4.86	4.81	4.72	3.77	3.54
	Sensitive capacity kW	3.92	3.89	3.85	3.77	3.02	2.83
	Input kW.	5.29	5.26	5.22	5.11	5.27	5.47
24°C D 17°C W	Total capacity kW	5.02	4.97	4.92	4.82	3.86	3.62
	Sensitive capacity kW	4.01	3.97	3.94	3.86	3.09	2.89
	Input kW.	1.85	1.84	1.82	1.79	1.84	1.91
27°C D 19°C W	Total capacity kW	5.51	5.46	5.41	5.30	4.24	3.98
	Sensitive capacity kW	4.41	4.37	4.32	4.24	3.39	3.18
	Input kW.	1.89	1.88	1.87	1.83	1.88	1.96
32°C D 23°C W	Total capacity kW	6.17	6.11	6.05	5.94	4.75	4.45
	Sensitive capacity kW	4.94	4.89	4.84	4.75	3.80	3.56
	Input kW.	2.12	2.11	2.09	2.05	2.11	2.19

Heating		OUTDOOR CONDITIONS						
Indoor Conditions		24°C D	12°C D	7°C D	4°C D	0°C D	-4°C D	-7°C D
		18°C W	11°C W	6°C W	3°C W	-1°C W	-6°C W	-8°C W
15°C	Capacity kW	7.69	7.61	6.66	5.46	4.66	3.66	3.40
	Input kW.	2.41	2.38	2.08	1.93	1.88	1.66	1.61
18°C	Capacity kW	7.35	7.26	6.36	5.22	4.45	3.50	3.24
	Input kW.	2.30	2.27	1.99	1.84	1.80	1.58	1.54
20°C	Capacity kW	6.93	6.85	6.00	4.92	4.20	3.30	3.06
	Input kW.	2.17	2.15	1.88	1.74	1.70	1.50	1.46
22°C	Capacity kW	5.89	5.82	5.10	4.18	3.57	2.81	2.60
	Input kW.	2.00	1.98	1.73	1.61	1.57	1.38	1.34

6. Wiring Diagrams

SIB-50BAV

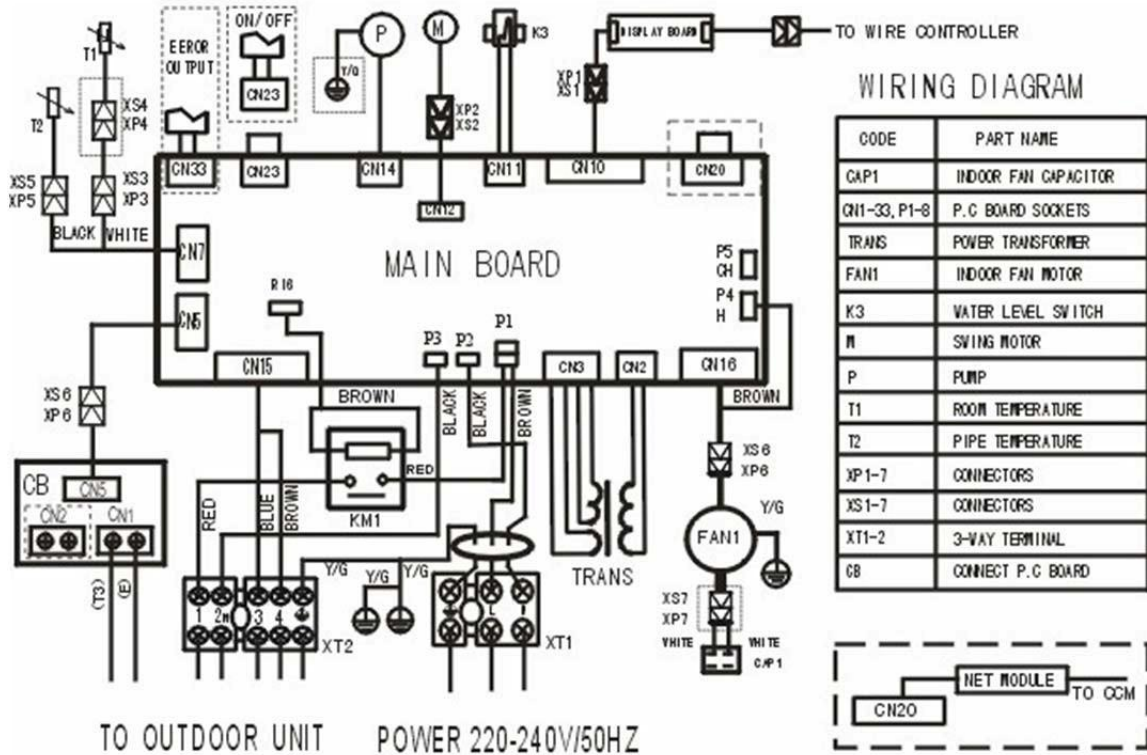

7. Air Velocity and Temperature Distributions

Airflow velocity

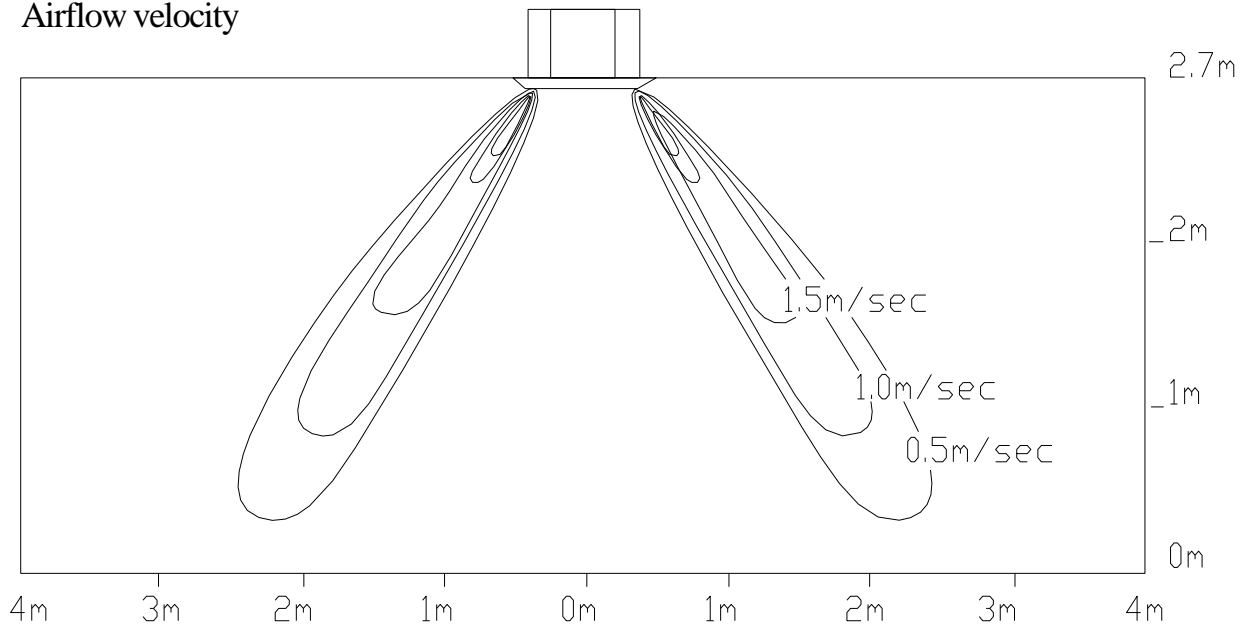

Temperature

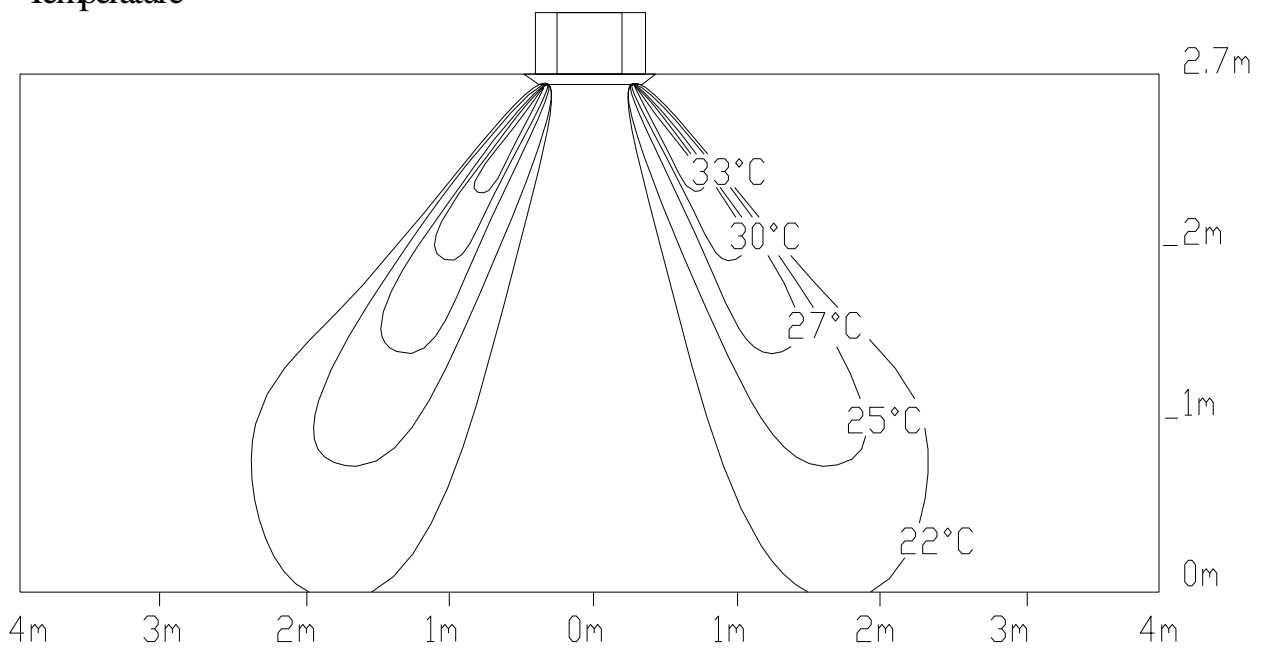

8. Electric Characteristics

Model	Indoor Units				Power Supply
	Hz	Voltage	Min.	Max.	MFA
SIB-50BAV	50	220-240V	198V	254V	25

Remark:

MFA: Max. Fuse Amps. (A)

9. Sound Levels

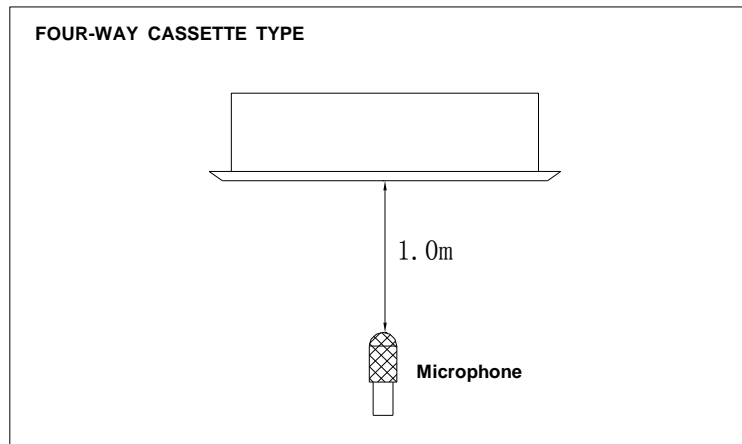

Model	Noise level dB(A)		
	H	M	L
SIB-50BAV	44	41	38

10. The Specification of Power

Type		SIB-50BAV
Power	Phase	1-phase
	Frequency and Voltage	220-240V, 50Hz
Circuit Breaker/ Fuse (A)		40/25
Indoor Unit Power Wiring (mm ²)		3×2.5
Indoor/Outdoor Connecting Wiring	Ground wire(mm ²)	2.5
	Outdoor Unit Power Wiring	—————
	Strong Electric Signal	5×2.5
	Weak Electric Signal (mm ²)	2-core shield wire 2×0.75

11. Field Wiring

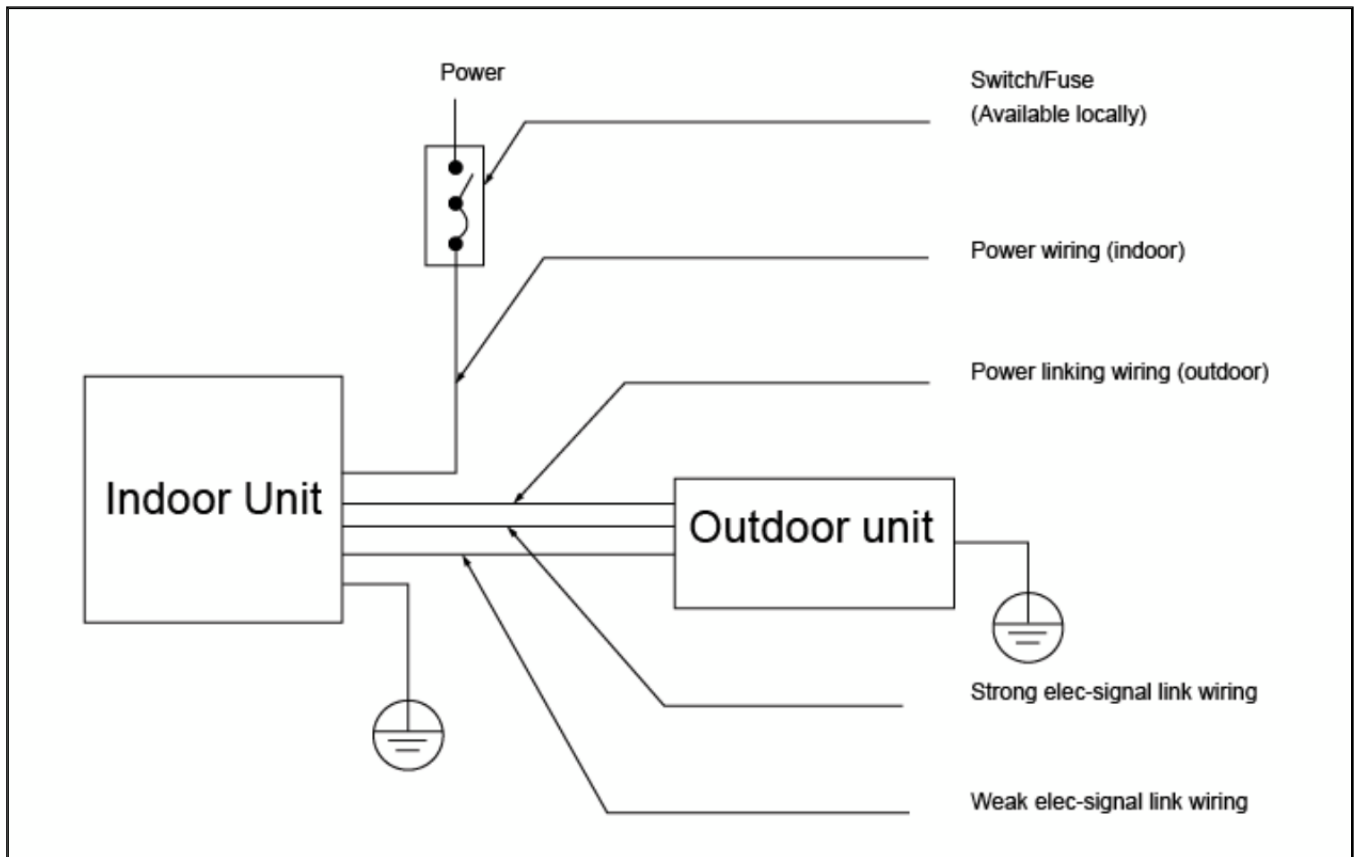

SIB-50BAV

Air Condition Link-Circuit

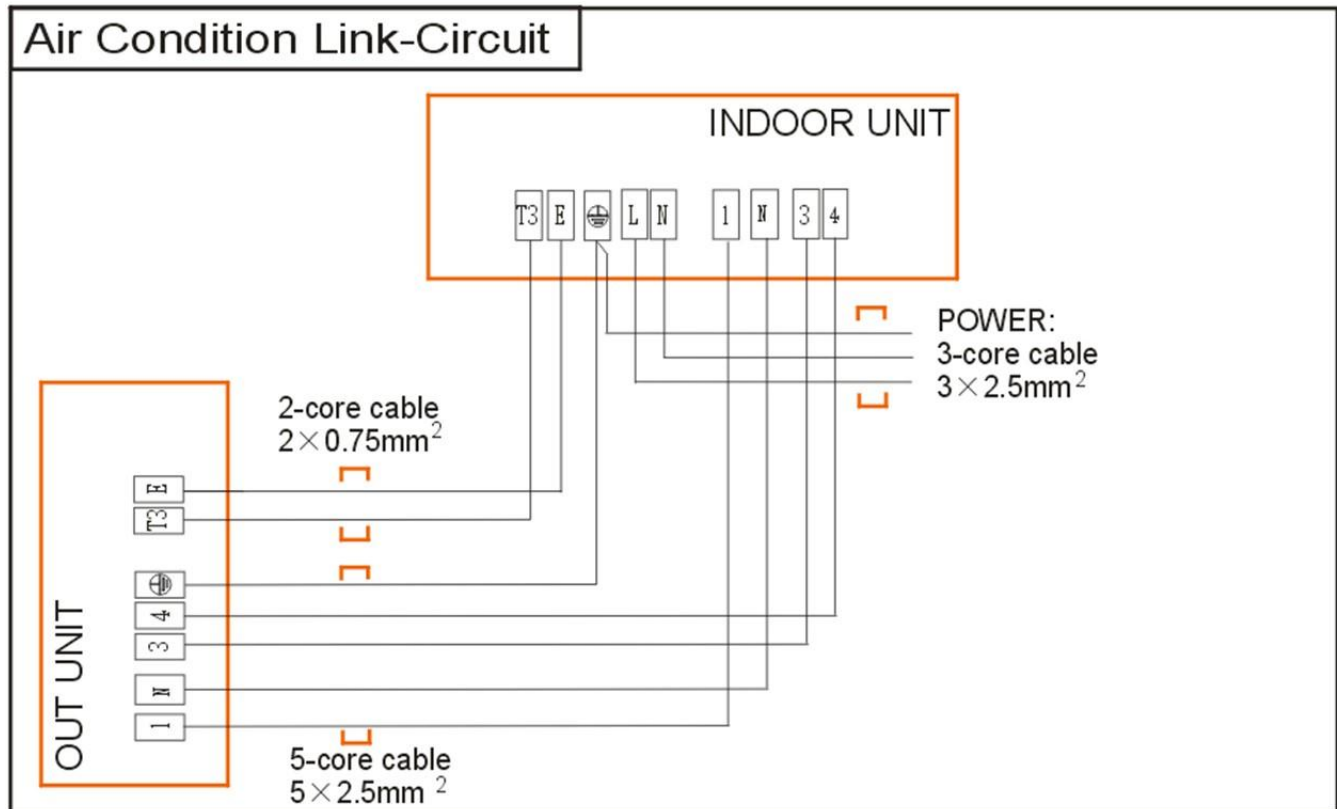

Four-way Cassette Type

1. Features	22
2. Specifications.....	25
3. Dimensions.....	27
4. Service Space.....	28
5. Capacity tables.....	29
6. Wiring Diagrams.....	33
7. Air Velocity and Temperature Distributions	35
8. Electric Characteristics	36
9. Sound Levels.....	37
10. The Specification of Power	38
11. Field Wiring.....	39

1. Features

- (1) Low operation noise
 - Streamline plate ensures quietness
 - Creates natural and comfortable environment
- (2) Efficient cooling - Equal, fast and wide range cooling

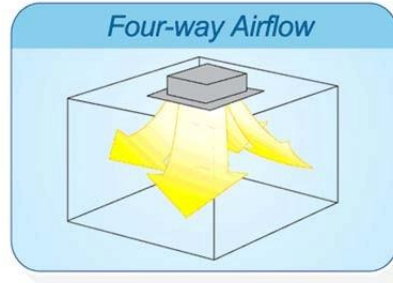

- (3) Excellent performance. The optimal evaporator & sufficient airflow volume guarantees the excellent capacity
- (4) The adoption of the most advanced 3- Dimensional Screw fan
 - Reduces the air resistance passing through
 - Smoothes the air flow
 - Makes air speed distribution to the heat exchange uniform

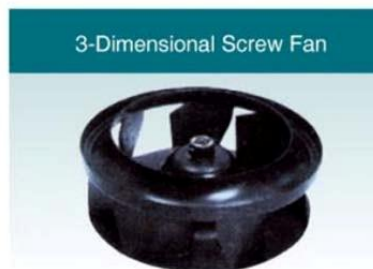

- (5) Fresh air makes life healthier and more comfortable.



- (6) Drainage pump can take up the condenser water to 750mm.

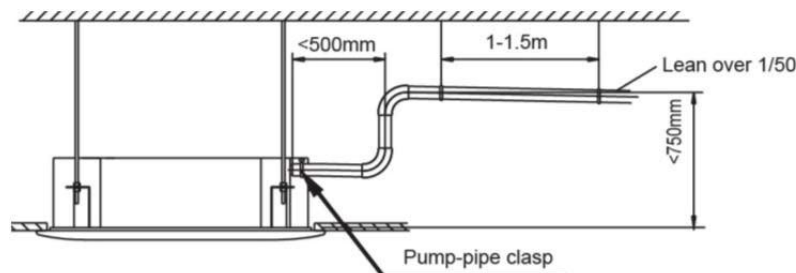

- (7) Ultra-thin machine body to easy installation and maintenance. 24K:230mm, 36~60K:300mm.

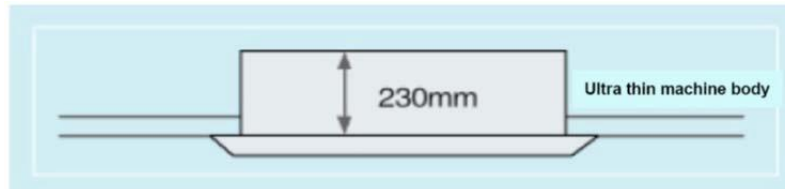

(8) Swing angle of louver

- 1) Add one more swing motor, one motor driving two louvers. Controlling the interspace of each part, minimizing the angle loss.
- 2) The swing angle of the first louver are 40~42 degrees and the second louver are 37~38 degrees. New evaporator and inner configuration designed can acquire high heat-exchanger effect.

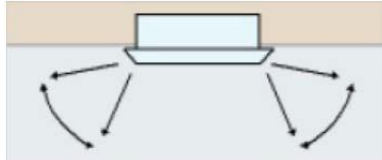

(9) More strengthening rib design around the panel, preventing the distortion for the panel.

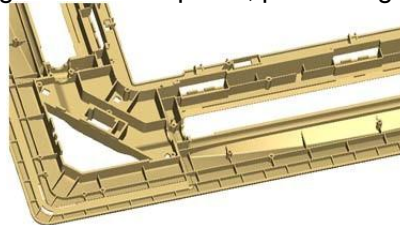

(10) New outlet frame design to make the phenomena of coagulation great improvement: prevent the condensing water from damaging the air guide strip.

(11) Adding rib on the panel of fan outlet, which can avoid the air outlet direct flow to people.

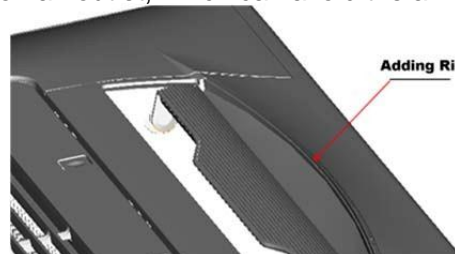

(12) Adding digital tube displaying on the display board. LED can display the Error Code to make the malfunction checking easier.



(13) Reserve spaces for air side-outlet, it is available to connect duct pipe hence air supplying from the four sides to nearby small room..

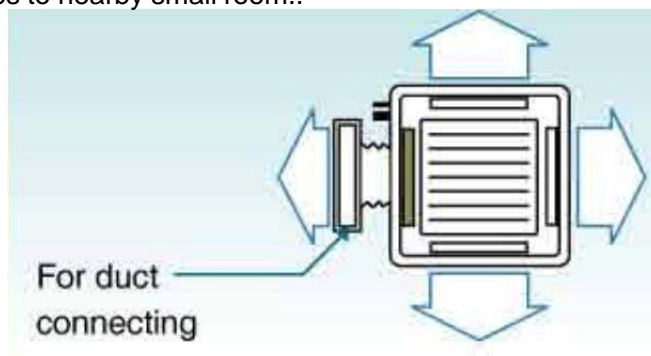

(14) The connecting pipe and drop height is higher. Max. pipe length up to 50m (refer to ①) , and Max. drop height up to 30m (refer to ②) .

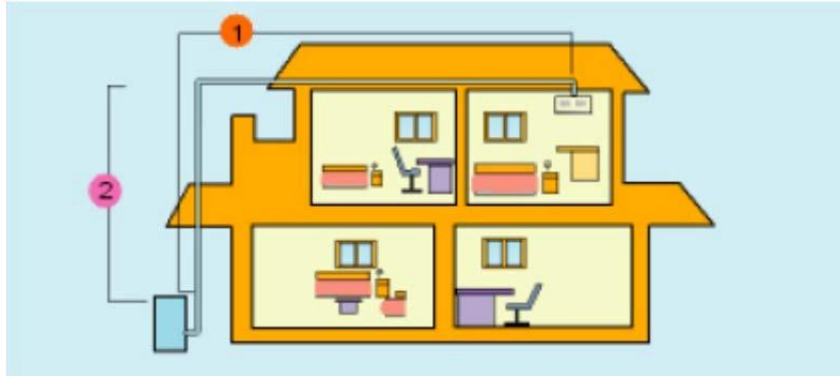

(15) Optimal design, smaller Control Box, Space saving and convenient for wiring, Using fire resistance galvanized steel for E-box material. Metal box make the control part more stable and prevent damaging.

(16) 360° air flow panel : 360° air flow delivery ensures uniform airflow distribution.

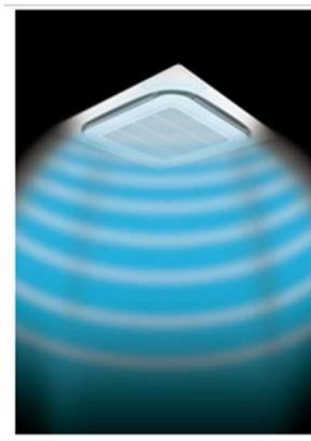

2. Specifications

Model			SIB-60BAV	SIB-100BAY
Power supply		V-Ph-Hz	220~240-1-50	380~415-3-50
Cooling	Capacity	Btu/h	24000	36000
		kW	7.03	10.5
	Input	W	2475	3780
	EER		2.87	2.78
Heating	Capacity	Btu/h	26000	40000
		kW	7.62	11.72
	Input	W	2428	4250
	COP		3.13	6.5
Indoor fan motor	Model		YDK80-6E	YDK90-6E
	Qty		1	1
	Input	W	120/100/ 90	143/116/100
	Capacitor	uF	3uF/450V	3.5uF/450V
	Speed(Hi/Mi/Lo)	r/min	800/550/400	770/640/550
Indoor coil	Number of rows		2	2
	Tube pitch(a)×row pitch(b)	mm	21×13.37	21×13.37
	Fin spacing	mm	1.5	1.5
	Fin type (code)		Hydrophilic aluminum	Hydrophilic aluminum
	Tube outside dia. and type	mm	∅7 Inner grooved copper tube	∅7 Inner grooved copper tube
	Coil length × height × width	mm	1990×168×26.74	1990×168×26.74
	Number of circuits		8	1
Indoor air flow (Hi/Mi/Lo)		m ³ /h	940/790/655	1545/1354/1187
Indoor noise level (sound pressure)		dB(A)	42/40/39	44/42/41
Indoor unit	Dimension (W×H×D)(body)	mm	840×230×840	840×300×840
	Packing (W×H×D)(body)	mm	900×250×900	900×320×900
	Dimension (W×H×D)(panel)	mm	950×55×950	950×55×950
	Packing (W×H×D)(panel)	mm	1035×90×1035	1035×90×1035
	Net/Gross weight(body)	kg	24/30	30/33
	Net/Gross weight(panel)	kg	6/9	6/9
Refrigerant type			R410A	R410A
Design pressure		MPa	4.2/1.5	4.2/1.5
Refrigerant piping	Liquid side/Gas side	mm	∅9.5/∅15.9	∅12.7/∅19
Drainage water pipe diameter		mm	OD∅32	OD∅32
Controller			RG36C/BG(C)E	RG36C/BG(C)E
Operation temperature		°C	17-30	17-30

- Notes:**
- Nominal cooling capacities are based on the following conditions:
Indoor temp: 27°CDB, 19°CWB; Outdoor temp: 35°CDB; Equivalent ref. piping: 7.5m (horizontal)
 - Nominal heating capacities are based on the following conditions:
Indoor temp: 20°CDB; Outdoor temp: 7°CDB, 6°CWB; Equivalent ref. piping: 7.5m (horizontal)
 - Actual noise level may differ, depending on the room structure, etc, since these noise values are from an anechoic room.

Model			SIB-140BAY	SIB-200BAY
Power supply		V-ph-Hz	380~415-3-50	380~415-3-50
Cooling	Capacity	Btu/h	48000	60000
		kW	14.07	17.6
	Input	W	4880	5904
	EER		2.87	2.71
Heating	Capacity	Btu/h	52000	65000
		kW	15.24	19.0
	Input	W	5290	6859
	Current	A	9.1	10.6
	COP		2.83	2.77
Indoor fan motor	Model		YDK90-6E	YDK90-6E
	Qty		1	1
	Input	W	143/116/100	165/116/100
	Capacitor	uF	3.5uF/450V	4UF/450V
	Speed(Hi/Mi/Lo)	r/min	770/640/550	840/640/550
Indoor coil	Number of rows		2	3
	Tube pitch(a)×row pitch(b)	mm	21×13.37	21×13.37
	Fin spacing	mm	1.5	1.5
	Fin type (code)		Hydrophilic aluminum	Hydrophilic aluminum
	Tube outside dia.and type	mm	∅7 Inner grooved copper tube	∅7 Inner grooved copper tube
	Coil length × height × width	mm	1990×252×26.74	2080×252×40.11
	Number of circuits		12	12
Indoor air flow (Hi/Mi/Lo)		m ³ /h	1545/1354/1187	1800/1480/1280
Indoor noise level (sound pressure)		dB(A)	44/42/41	47/44/43
Indoor unit	Dimension (W×H×D)(body)	mm	840×300×840	840×300×840
	Packing (W×H×D)(body)	mm	900×320×900	900×320×900
	Dimension (W×H×D)(panel)	mm	950×55×950	950×55×950
	Packing (W×H×D)(panel)	mm	1035×90×1035	1035×90×1035
	Net/Gross weight(body)	kg	29/32	32/36
	Net/Gross weight(panel)	kg	6/9	6/9
Refrigerant type			R410A	R410A
Design pressure		MPa	4.2/1.5	4.2/1.5
Refrigerant piping	Liquid side/Gas side	mm	∅12.7/∅19	∅12.7/∅19
Drainage water pipe diameter		mm	OD∅32	OD∅32
Controller			RG36C/BG(C)E	RG36C/BG(C)E
Operation temperature		°C	17-30	17-30

- Notes:**
- Nominal cooling capacities are based on the following conditions:
Indoor temp: 27°CDB, 19°CWB; Outdoor temp: 35°CDB; Equivalent ref. piping: 7.5m (horizontal)
 - Nominal heating capacities are based on the following conditions:
Indoor temp: 20°CDB; Outdoor temp: 7°CDB, 6°CWB; Equivalent ref. piping: 7.5m (horizontal)
 - Actual noise level may differ, depending on the room structure, etc, since these noise values are from an anechoic room.

3. Dimensions

SIB-60BAV

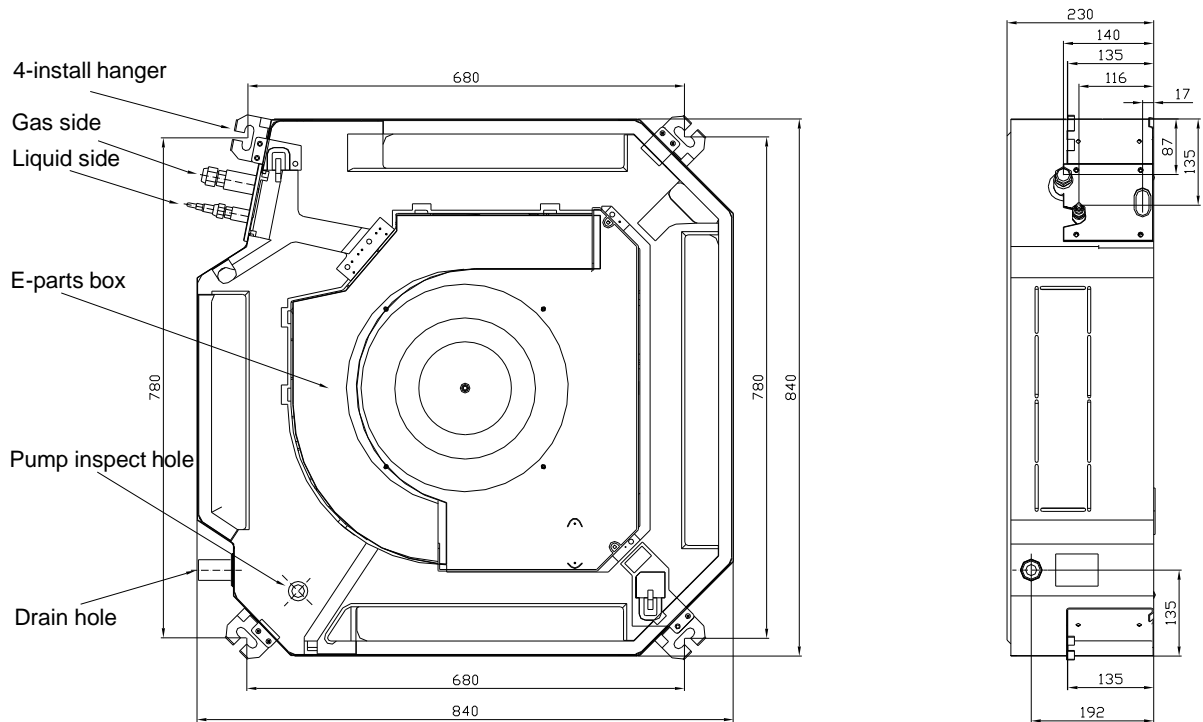

SIB-100BAY

SIB-140BAY

SIB-200BAY

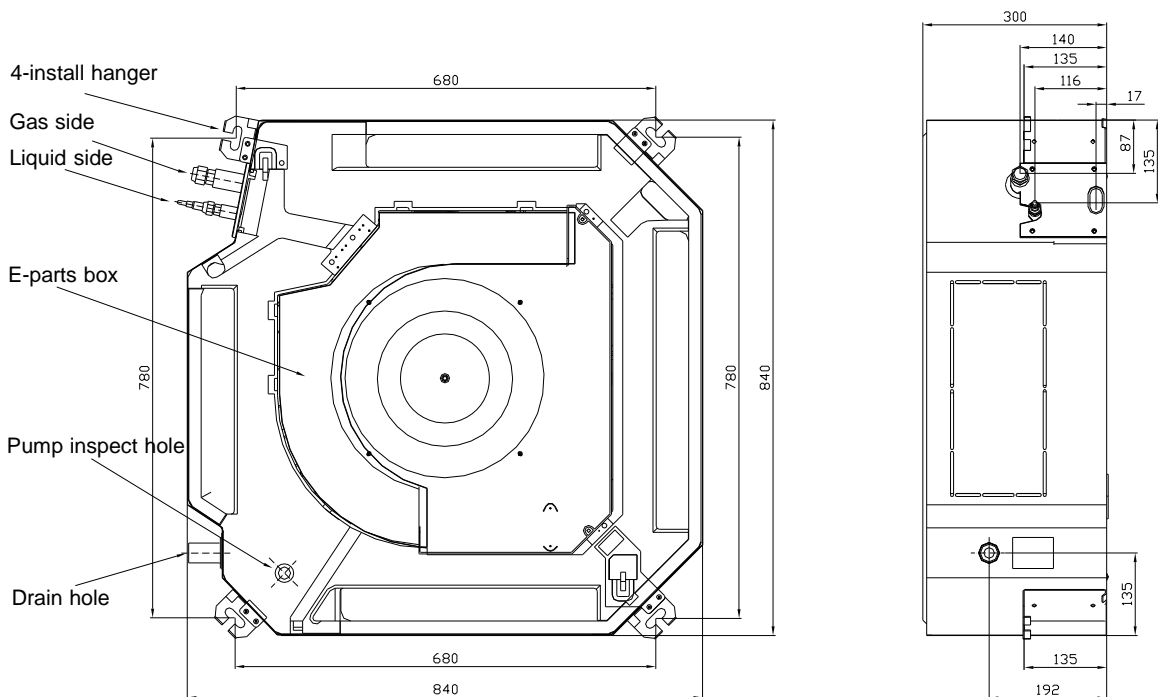

4. Service Space

The indoor unit should be installed in a location that meets the following requirements:

- There is enough room for installation and maintenance.
- The ceiling is horizontal, and its structure can endure the weight of the indoor unit.
- The outlet and the inlet are not impeded, and the influence of external air is the least.
- The air flow can reach throughout the room.
- The connecting pipe and drainpipe could be extracted out easily.
- There is no direct radiation from heaters.

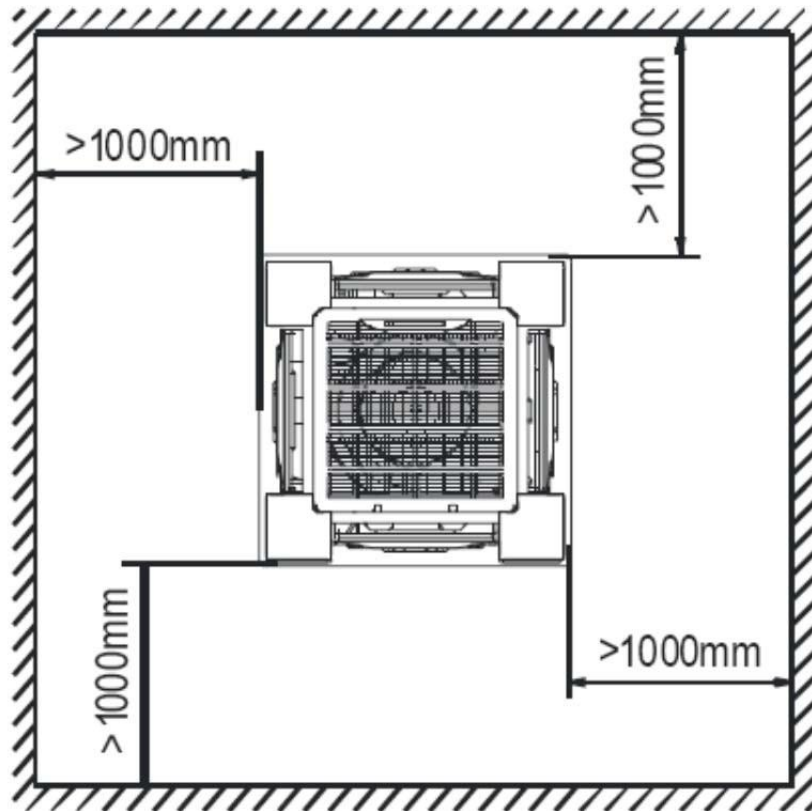

5. Capacity tables

5.1 SIB-60BAV

Cooling

Cooling		Outdoor conditions (DB)				
Indoor Conditions	(kW)	18°C	21°C	28°C	35°C	43°C
21/15°C DB/WB	TC	7.53	7.31	6.96	6.60	6.32
	SC	5.49	5.41	5.36	5.28	5.31
	Input	1.98	2.05	2.23	2.33	2.40
24/17°C DB/WB	TC	7.74	7.53	7.17	6.82	6.39
	SC	5.73	5.64	5.59	5.52	5.37
	Input	2.10	2.18	2.33	2.43	2.55
27/19°C DB/WB	TC	7.88	7.67	7.31	7.10	6.60
	SC	5.75	5.67	5.63	5.54	5.41
	Input	2.15	2.23	2.35	2.48	2.60
32/23°C DB/WB	TC	8.09	7.81	7.53	7.38	6.82
	SC	6.80	6.64	6.55	6.50	6.34
	Input	2.25	2.33	2.43	2.60	2.70

Heating

Heating		Outdoor conditions				
Indoor Conditions (DB)	(kW)	24/18°C DB/WB	7/6°C DB/WB	2/1°C DB/WB	-5/-6°C DB/WB	-7/-8°C DB/WB
15°C	TC	9.88	7.98	6.54	5.93	5.55
	Input	2.62	2.26	1.94	1.82	1.72
20°C	TC	9.58	7.60	6.16	5.78	5.32
	Input	2.87	2.43	2.14	1.97	1.85
27°C	TC	8.97	7.14	5.78	5.62	5.02
	Input	3.04	2.62	2.31	2.14	1.99

Remark:

TC : Total capacity ; kW

SC: Sensible heat capacity ; kW

Input: Input power ; kW

5.2 SIB-100BAY

Cooling

Cooling		Outdoor conditions (DB)				
Indoor Conditions	(kW)	18°C	21°C	28°C	35°C	43°C
21/15°C DB/WB	TC	11.13	10.82	10.29	9.77	9.35
	SC	8.12	8.00	7.92	7.81	7.85
	Input	3.17	3.29	3.57	3.73	3.85
24/17°C DB/WB	TC	11.45	11.13	10.61	10.08	9.45
	SC	8.47	8.35	8.27	8.16	7.94
	Input	3.37	3.49	3.73	3.89	4.09
27/19°C DB/WB	TC	11.66	11.34	10.82	10.50	9.77
	SC	8.51	8.39	8.33	8.19	8.01
	Input	3.45	3.57	3.77	3.97	4.17
32/23°C DB/WB	TC	11.97	11.55	11.13	10.92	10.08
	SC	10.05	9.82	9.68	9.61	9.37
	Input	3.61	3.73	3.89	4.17	4.32

Heating

Heating		Outdoor conditions				
Indoor Conditions (DB)	(kW)	24/18°C DB/WB	7/6°C DB/WB	2/1°C DB/WB	-5/-6°C DB/WB	-7/-8°C DB/WB
15°C	TC	15.60	12.60	10.32	9.36	8.76
	Input	4.40	3.79	3.26	3.05	2.89
20°C	TC	15.12	12.00	9.72	9.12	8.40
	Input	4.80	4.07	3.58	3.30	3.09
27°C	TC	14.16	11.28	9.12	8.88	7.92
	Input	5.09	4.40	3.87	3.58	3.34

Remark:

TC : Total capacity ; kW

SC: Sensible heat capacity ; kW

Input: Input power ; kW

5.3 SIB-140BAY

Cooling

Cooling		Outdoor conditions (DB)				
Indoor Conditions	(kW)	18°C	21°C	28°C	35°C	43°C
21/15°C DB/WB	TC	14.48	14.07	13.39	12.70	12.16
	SC	10.57	10.41	10.31	10.16	10.21
	Input	4.28	4.45	4.82	5.03	5.20
24/17°C DB/WB	TC	14.89	14.48	13.80	13.11	12.29
	SC	11.02	10.86	10.76	10.62	10.33
	Input	4.55	4.71	5.03	5.25	5.52
27/19°C DB/WB	TC	15.16	14.75	14.07	13.66	12.70
	SC	11.07	10.92	10.83	10.65	10.42
	Input	4.66	4.82	5.09	5.36	5.62
32/23°C DB/WB	TC	15.57	15.03	14.48	14.21	13.11
	SC	13.08	12.77	12.60	12.50	12.20
	Input	4.87	5.03	5.25	5.62	5.84

Heating

Heating		Outdoor conditions				
Indoor Conditions (DB)	(kW)	24/18°C DB/WB	7/6°C DB/WB	2/1°C DB/WB	-5/-6°C DB/WB	-7/-8°C DB/WB
15°C	TC	19.50	15.75	12.90	11.70	10.95
	Input	6.02	5.19	4.46	4.18	3.96
20°C	TC	18.90	15.00	12.15	11.40	10.50
	Input	6.58	5.58	4.91	4.52	4.24
27°C	TC	17.70	14.10	11.40	11.10	9.90
	Input	6.97	6.02	5.30	4.91	4.57

Remark:

TC : Total capacity ; kW

SC: Sensible heat capacity ; kW

Input: Input power ; kW

5.4 SIB-200BAY

Cooling

Cooling		Outdoor conditions (DB)				
Indoor Conditions	(kW)	18°C	21°C	28°C	35°C	43°C
21/15°C DB/WB	TC	16.96	16.48	15.68	14.88	14.24
	SC	12.38	12.20	12.07	11.90	11.96
	Input	4.90	5.09	5.52	5.76	5.95
24/17°C DB/WB	TC	17.44	16.96	16.16	15.36	14.40
	SC	12.91	12.72	12.60	12.44	12.10
	Input	5.21	5.39	5.76	6.01	6.31
27/19°C DB/WB	TC	17.76	17.28	16.48	16.00	14.88
	SC	12.96	12.79	12.69	12.48	12.20
	Input	5.33	5.52	5.82	6.13	6.44
32/23°C DB/WB	TC	18.24	17.60	16.96	16.64	15.36
	SC	15.32	14.96	14.76	14.64	14.28
	Input	5.58	5.76	6.01	6.44	6.68

Heating

Heating		Outdoor conditions				
Indoor Conditions (DB)	(kW)	24/18°C DB/WB	7/6°C DB/WB	2/1°C DB/WB	-5/-6°C DB/WB	-7/-8°C DB/WB
15°C	TC	22.88	18.48	15.14	13.73	12.85
	Input	6.39	5.51	4.74	4.44	4.20
20°C	TC	22.18	17.60	14.26	13.38	12.32
	Input	6.99	5.92	5.21	4.80	4.50
27°C	TC	20.77	16.54	13.38	13.02	11.62
	Input	7.40	6.39	5.62	5.21	4.86

Remark:

TC : Total capacity ; kW

SC: Sensible heat capacity ; kW

Input: Input power ; kW

6. Wiring Diagrams

6.1 SIB-60BAV

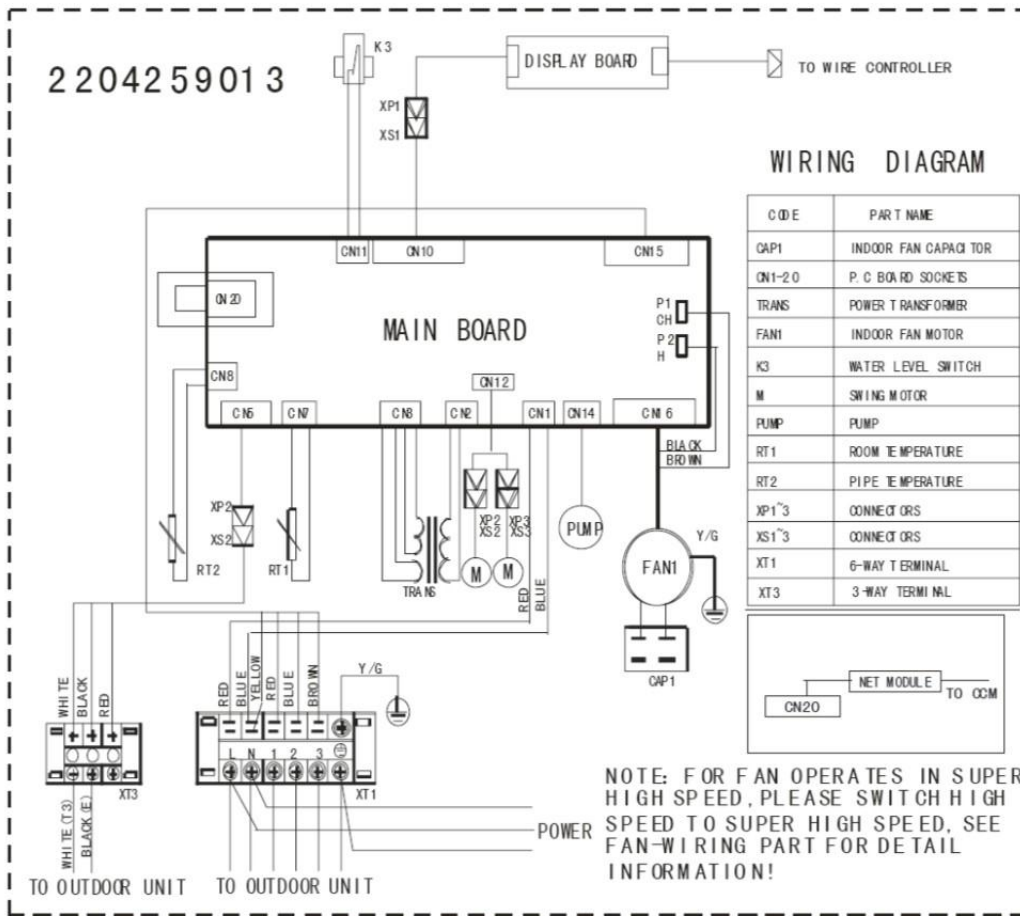

6.2 SIB-100BAY SIB-140BAY

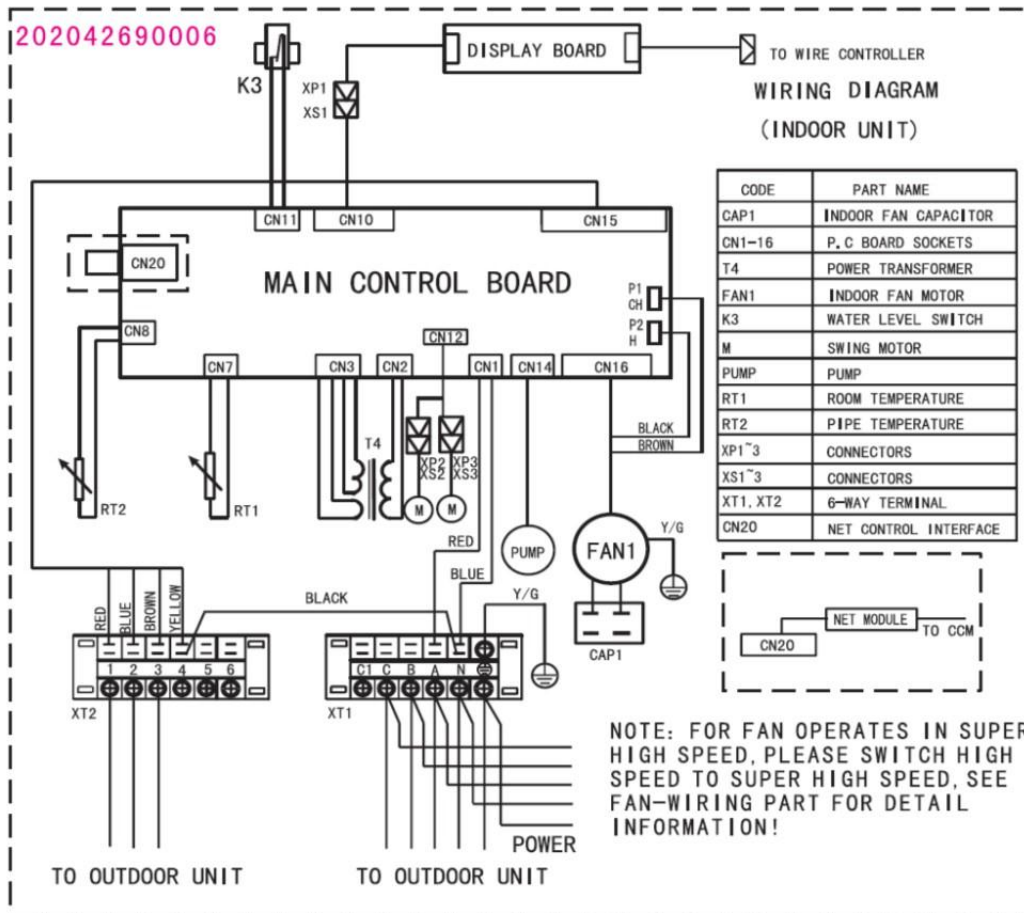

6.3 SIB-200BAY

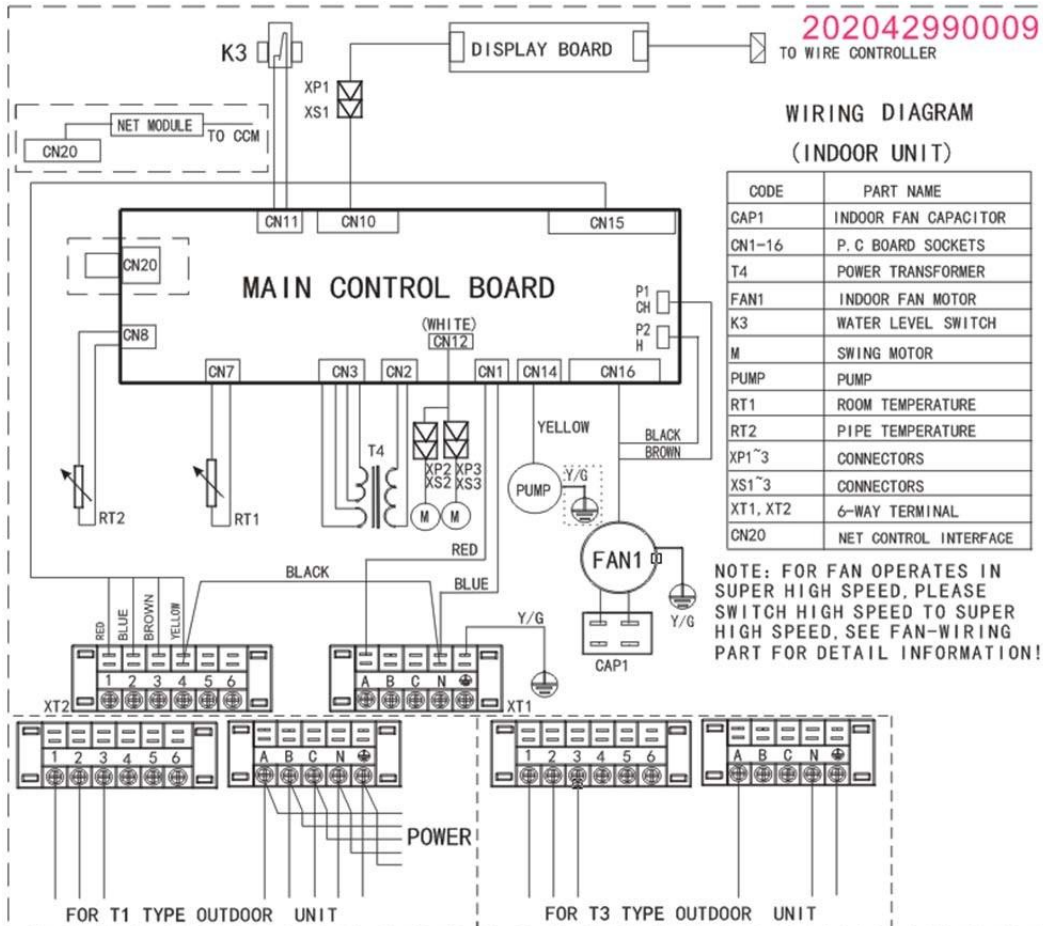

7. Air Velocity and Temperature Distributions

Airflow velocity

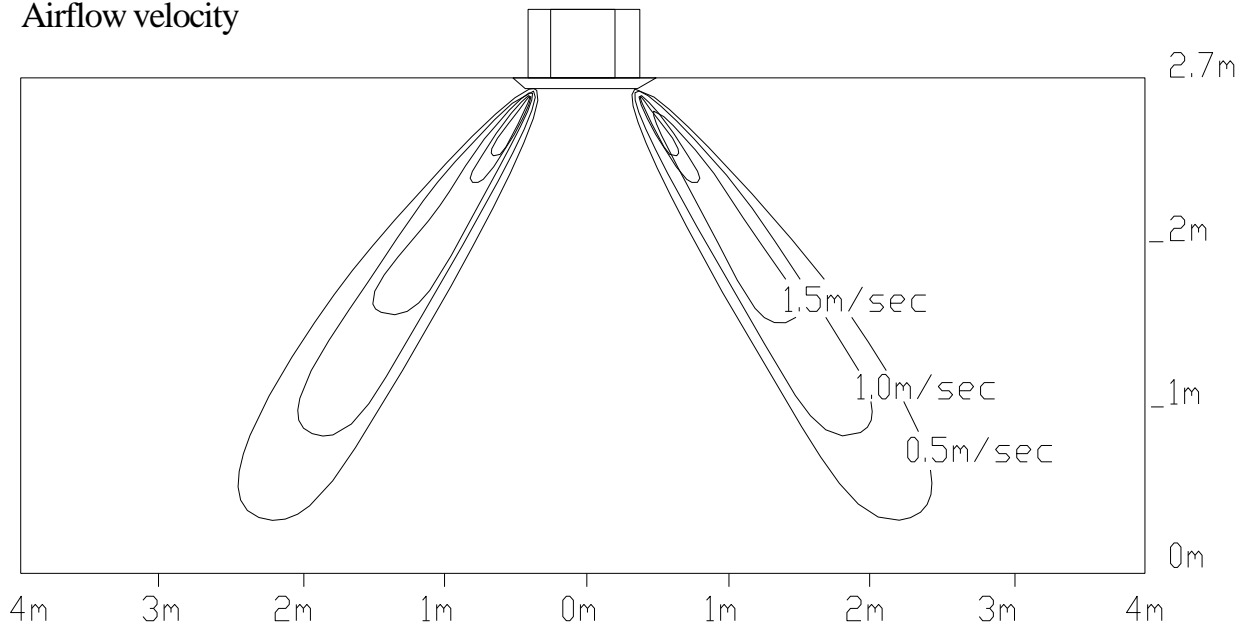

Temperature

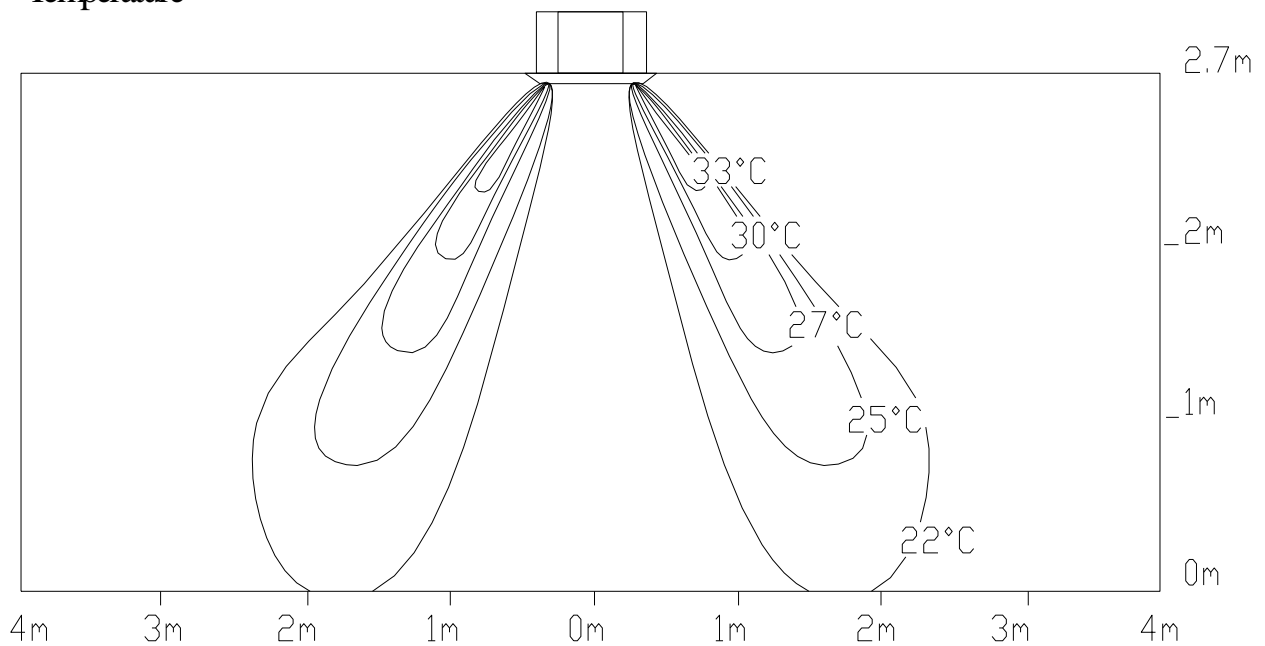

8. Electric Characteristics

Model	Indoor Units				Power Supply
	Hz	Voltage	Min.	Max.	MFA
SIB-60BAV	50	220-240V	198V	254V	25
SIB-100BAY	50	380-415V	342V	418V	15
SIB-140BAY	50	380-415V	342V	418V	15
SIB-200BAY	50	380-415V	342V	418V	25

Remark:

MFA: Max. Fuse Amps. (A)

9. Sound Levels

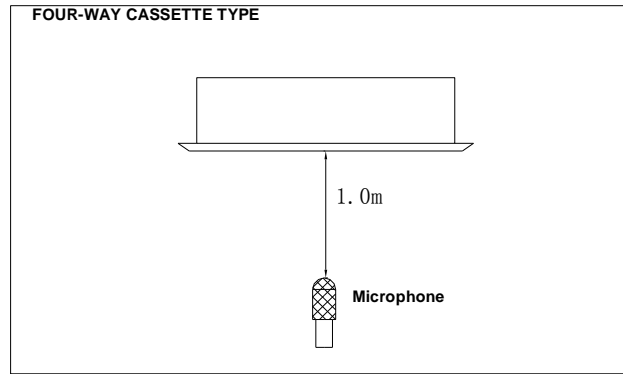

Model	Noise level dB(A)		
	H	M	L
SIB-60BAV	42	40	39
SIB-100BAY	44	42	41
SIB-140BAY	44	42	41
SIB-200BAY	47	44	43

10. The Specification of Power

Cooling & heating

Type		24000 Btu/h	36000-48000 Btu/h	60000 Btu/h
Power	Phase	1-phase	3-phase	3-phase
	Frequency and Voltage	220-240V, 50Hz	380-415V, 50Hz	380-415V, 50Hz
Circuit Breaker/ Fuse (A)		40/25	25/15	40/25
Indoor Unit Power Wiring (mm ²)		3×2.5	5×2.5	5×2.5
Indoor/Outdoor Connecting Wiring (mm ²)	Ground Wiring	4.0	2.5	2.5
	Outdoor Unit Power Wiring	3×2.5	5×2.5	5×2.5
	Strong Electric Signal	3×2.5	3×1.0	3×2.5
	Weak Electric Signal	2-core shield wire 2×0.75	—————	—————

11. Field Wiring

Wiring chart

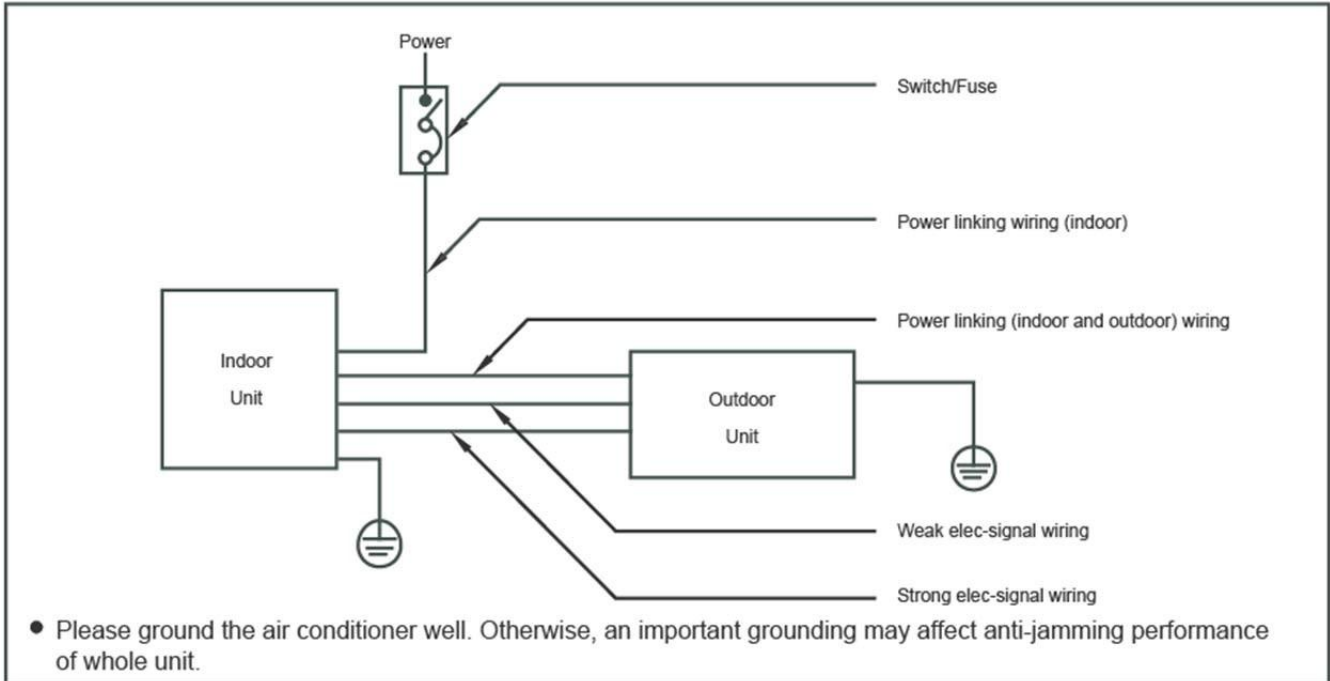

SIB-60BAV

Air Condition Link-Circuit

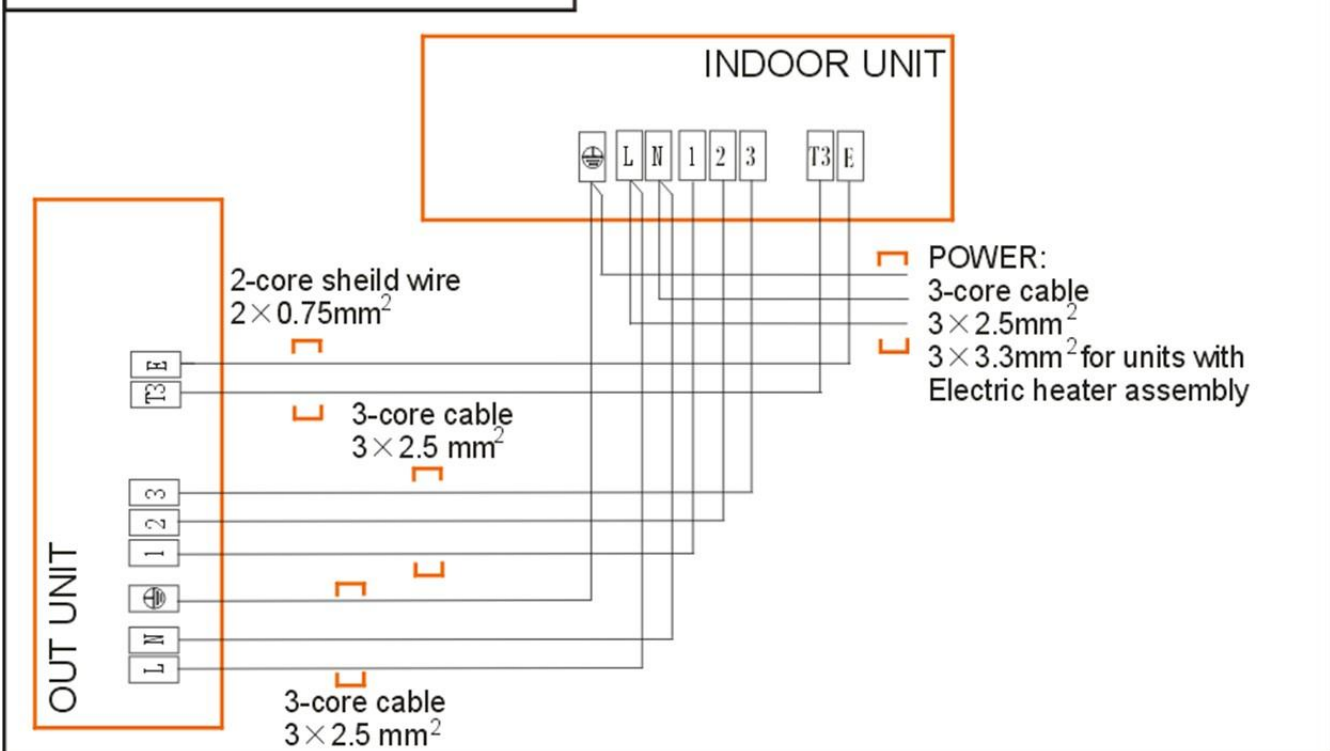

SIB-100BAY SIB-140BAY

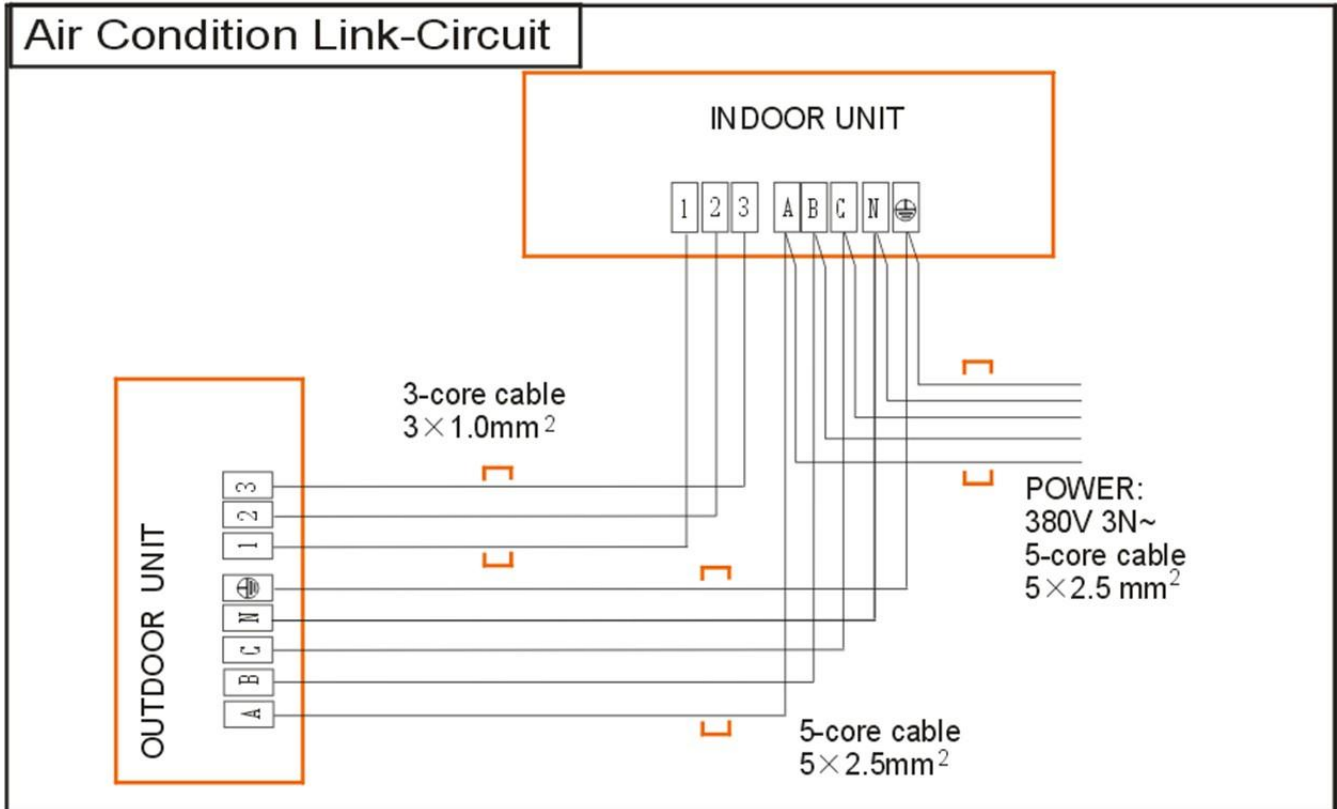

SIB-200BAY

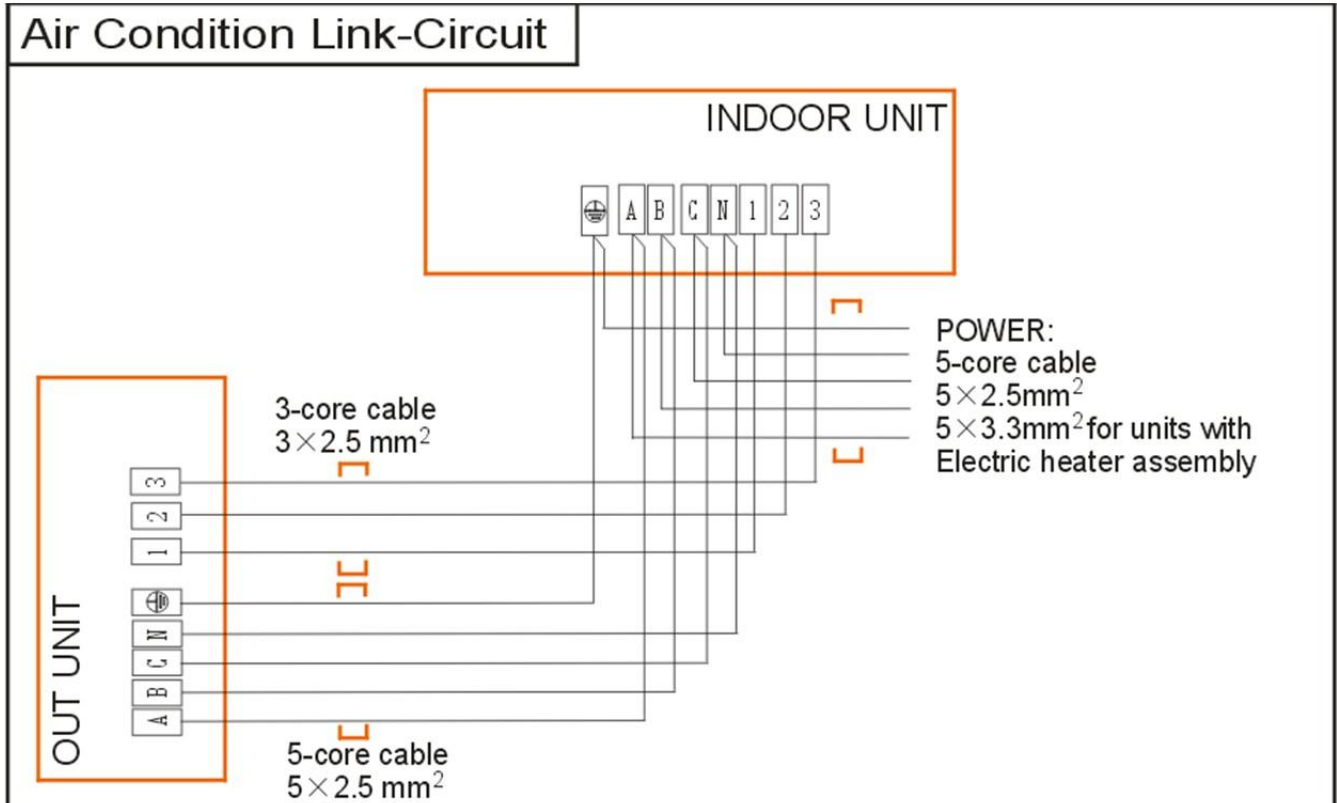

Ceiling & Floor Type

1. Features	42
2. Specifications	43
3. Dimensions.....	46
4. Service Space	47
5. Capacity tables	48
6. Wiring Diagrams	53
7. Air Velocity and Temperature Distributions	55
8. Electric Characteristics.....	57
9. Sound Levels.....	58
10. The Specification of Power.....	59
11. Field Wiring.....	60

1. Features

1.1. New design, more modern and elegant appearance.



1.2. Convenient installation

- The ceiling type can be easily installed into a corner of the ceiling even if the ceiling is very narrow
- It is especially useful when installation of an air conditioner in the center of the ceiling is impossible due to a structure such as one lighting.

1.3. Two direction auto swing (vertical & horizontal) and wide angle air flow

- Air flow directional control minimizes the air resistance and produces wilder air flow to vertical direction.
- The range of horizontal air discharge is widened which secures wider air flow distribution to provide more comfortable air circulation no matter where the unit is set up



1.4. Three level fan speed, more humanism design, meets different air-supply requirement

1.5. Water proof by utilizing the absorbing plastic film on water collector

1.6. Easy operation. Auto-restart function, remote control and optional wire control method

1.7. Low noise level plus compact size

- Shape of the blades has been improved to prevent noise caused by turbulence.

2. Specifications

Model			SIB-50TAV	SIB-60TAV
Power supply		V-ph-Hz	220~240-1-50	220~240-1-50
Cooling	Capacity	Btu/h	18000	24000
		kW	5.28	7.0
	Input	W	1726	2423
	EER		3.07	2.93
Heating	Capacity	Btu/h	20000	26000
		kW	5.86	7.62
	Input	W	1863	2415
	COP		3.22	3.15
Indoor fan motor	Model		YSK55-4L	YSK55-4L
	Qty		1	1
	Input	W	125/105/85	125/105/85
	Capacitor	uF	2.5uF/450V	2.5uF/450V
	Speed(Hi/Mi/Lo)	r/min	1310/1190/1040	1310/1190/1040
Indoor coil	Number of rows		2	3
	Tube pitch(a)×row pitch(b)	mm	25.4×22	21×13.37
	Fin spacing	mm	1.3	1.3
	Fin type (code)		Hydrophilic aluminum	Hydrophilic aluminum
	Tube outside dia. and type	mm	∅7 Inner grooved copper tube	∅7 Inner grooved copper tube
	Coil length× height× width	mm	804×252×26.74	804×252×40.11
	Number of circuits		3	4
Indoor air flow(Hi/Mi/Lo)		m ³ /h	800/600/500	1200/900/700
Indoor noise level (sound pressure)		dB(A)	43/41/38	45/43/40
Indoor unit	Dimension (W×H×D)	mm	990×203×660	990×203×660
	Packing (W×H×D)	mm	1037×238×739	1037×238×739
	Net/Gross weight	kg	24/30	24/30
Refrigerant type			R410A	R410A
Design pressure		MPa	4.2/1.5	4.2/1.5
Refrigerant piping	Liquid side/Gas side	mm	∅6.4/∅12.7	∅9.5/∅15.9
Drainage water pipe diameter		mm	OD∅25	OD∅25
Controller			RG36C/BG(C)E	RG36C/BG(C)E
Operation temperature		°C	17-30	17-30

- Notes:**
- Nominal cooling capacities are based on the following conditions:
Indoor temp: 27°CDB, 19°CWB; Outdoor temp: 35°CDB; Equivalent ref. Piping: 7.5m(horizontal)
 - Nominal heating capacities are based on the following conditions:
Indoor temp: 20°CDB; Outdoor temp: 7°CDB, 6°CWB; Equivalent ref. Piping: 7.5m(horizontal)
 - Actual noise level may differ, depending on the room structure, etc, since these noise values are from an anechoic room.

Model			SIB-100TAY	SIB-140TAY
Power supply		V-ph-Hz	380~415-3-50	380~415-3-50
Cooling	Capacity	Btu/h	36000	48000
	Input	W	3737	5128
	EER		2.81	2.73
Heating	Capacity	Btu/h	40000	52000
	Input	W	4286	5376
	COP		2.8	2.79
Indoor fan motor	Model		YSK80-4A-2	YSK59-4D-4
	Qty		1	2
	Input	W	159/142/130	102/98/96
	Capacitor	uF	3.5uF/450V	2.5uF/450V
	Speed(Hi/Mi/Lo)	r/min	1290/1170/1060	1230/1130/1070
Indoor coil	Number of rows		3	3
	Tube pitch(a)×row pitch(b)	mm	21×13.37	25.4×22
	Fin spacing	mm	1.3	1.5
	Fin type (code)		Hydrophilic aluminum	Hydrophilic aluminum
	Tube outside dia. and type	mm	Φ7 Inner grooved copper tube	φ9.5 Inner grooved copper tube
	Coil length× height×width	mm	1095×252×40.11	1360×254×66
	Number of circuits		6	5
Indoor air flow(Hi/Mi/Lo)		m ³ /h	1400/1200/1000	2000/1800/1600
Indoor noise level (sound pressure)		dB(A)	45/43/40	50/47/45
Indoor unit	Dimension (W×H×D)	mm	1280×203×660	1670×240×680
	Packing (W×H×D)	mm	1327×238×739	1715×273×760
	Net/Gross weight	kg	35/42	46/53
Refrigerant type			R410A	R410A
Design pressure		MPa	4.2/1.5	4.2/1.5
Refrigerant piping	Liquid side/Gas side	mm	Ø12.7/Ø19	Ø12.7/Ø19
Drainage water pipe diameter		mm	ODØ25	ODØ25
Controller			RG36C/BG(C)E	RG36C/BG(C)E
Operation temperature		°C	17-30	17-30

Notes: 1. Nominal cooling capacities are based on the following conditions:

Indoor temp: 27°CDB, 19°CWB; Outdoor temp: 35°CDB; Equivalent ref. Piping: 7.5m(horizontal)

2. Nominal heating capacities are based on the following conditions:

Indoor temp: 20°CDB; Outdoor temp: 7°CDB, 6°CWB; Equivalent ref. Piping: 7.5m(horizontal)

3. Actual noise level may differ, depending on the room structure, etc, since these noise values are from an anechoic room.

Model		SIB-200TAY	
Power supply		V-ph-Hz	380~415-3-50
Cooling	Capacity	Btu/h	60000
	Input	W	5882
	EER		2.72
Heating	Capacity	Btu/h	650000
	Input	W	6835
	COP		2.78
Indoor fan motor	Model		YSK59-4D
	Qty		2
	Input	W	89.5/81.5/77.5
	Capacitor	uF	2.5uF/450V
	Speed(Hi/Mi/Lo)	r/min	1170/1070/995
Indoor coil	Number of rows		3
	Tube pitch(a)×row pitch(b)	mm	25.4×22
	Fin spacing	mm	1.7
	Fin type (code)		Hydrophilic aluminum
	Tube outside dia.and type	mm	φ9.5 Inner grooved copper tube
	Coil length×height×width	mm	1360×254×66
	Number of circuits		5
Indoor air flow(Hi/Mi/Lo)		m ³ /h	2000/1800/1600
Indoor noise level (sound pressure)		dB(A)	50/49/47
Indoor unit	Dimension (W×H×D)	mm	1670×240×680
	Packing (W×H×D)	mm	1715×273×760
	Net/Gross weight	kg	46/56
Refrigerant type			R410A
Design pressure		MPa	4.2/1.5
Refrigerant piping	Liquid side/Gas side	mm	Ø12.7/Ø19
Drainage water pipe diameter		mm	ODØ25
Controller			RG36C/BG(C)E
Operation temperature			17-30

- Notes:**
- Nominal cooling capacities are based on the following conditions:
Indoor temp: 27°CDB, 19°CWB; Outdoor temp: 35°CDB; Equivalent ref. Piping: 7.5m(horizontal)
 - Nominal heating capacities are based on the following conditions:
Indoor temp: 20°CDB; Outdoor temp: 7°CDB, 6°CWB; Equivalent ref. Piping: 7.5m(horizontal)
 - Actual noise level may differ, depending on the room structure, etc, since these noise values are from an anechoic room.

3. Dimensions

a. Wall mounting installation

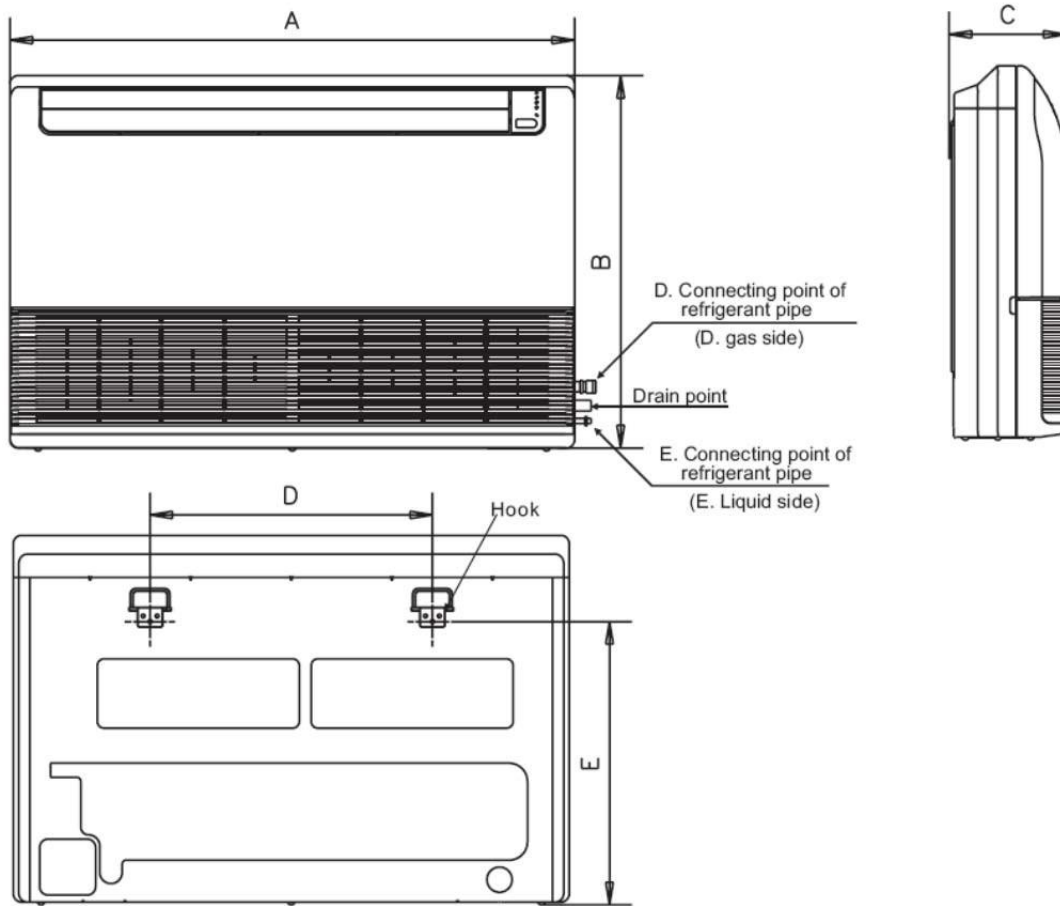

b. Ceiling installation

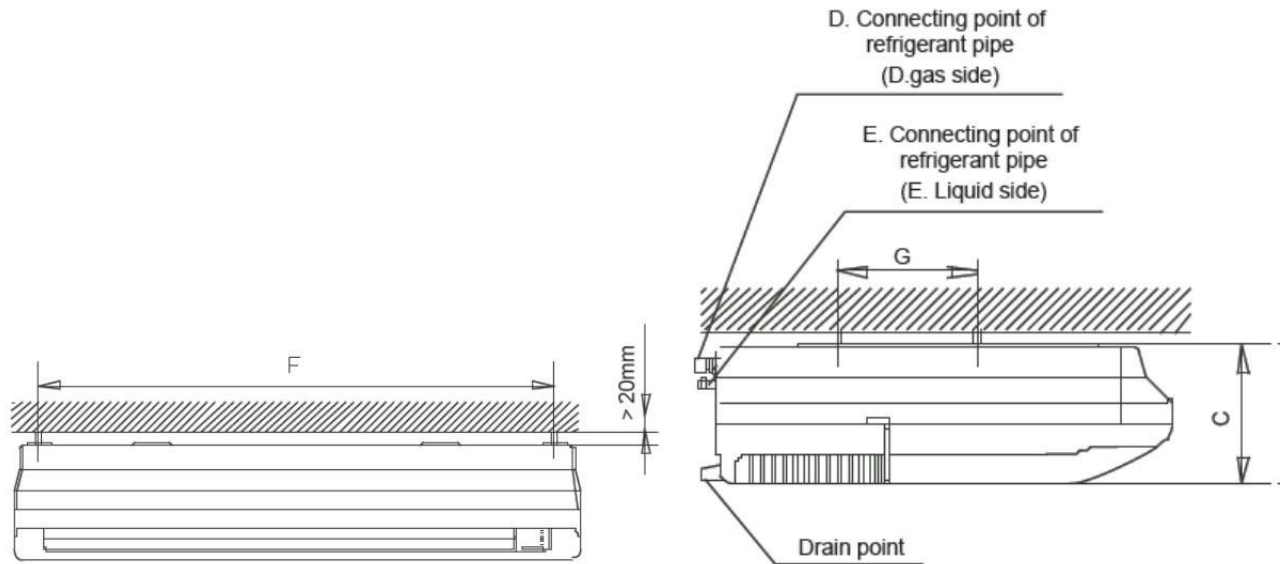

Capacity (Btu/h)	A	B	C	D	E	F	G
18000-24000	990	660	203	505	506	907	200
36000	1280	660	203	795	506	1195	200
48000-60000	1670	680	240	1070	450	1542	200

4. Service Space

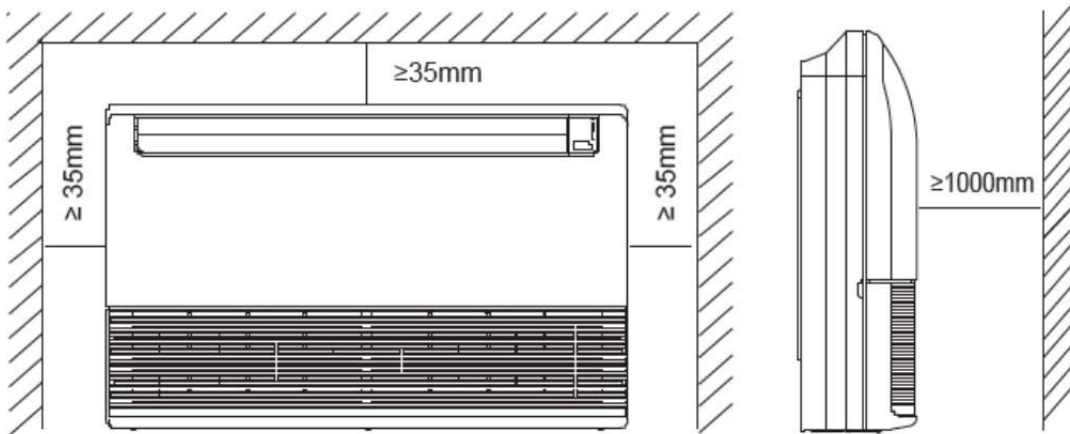

5. Capacity tables

5.1 SIB-50TAV

Cooling

Cooling		Outdoor conditions (DB)				
Indoor Conditions	(kW)	18°C	21°C	28°C	35°C	43°C
21/15°C DB/WB	TC	5.62	5.46	5.19	4.93	4.72
	SC	4.10	4.04	4.00	3.94	3.96
	Input	1.38	1.43	1.55	1.62	1.67
24/17°C DB/WB	TC	5.78	5.62	5.35	5.09	4.77
	SC	4.27	4.21	4.18	4.12	4.01
	Input	1.47	1.52	1.62	1.69	1.78
27/19°C DB/WB	TC	5.88	5.72	5.46	5.30	4.93
	SC	4.29	4.24	4.20	4.13	4.04
	Input	1.50	1.55	1.64	1.73	1.81
32/23°C DB/WB	TC	6.04	5.83	5.62	5.51	5.09
	SC	5.08	4.96	4.89	4.85	4.73
	Input	1.57	1.62	1.69	1.81	1.88

Heating

Heating		Outdoor conditions				
Indoor Conditions (DB)	(kW)	24/18°C DB/WB	7/6°C DB/WB	2/1°C DB/WB	-5/-6°C DB/WB	-7/-8°C DB/WB
15°C	TC	7.80	6.30	5.16	4.68	4.38
	Input	2.01	1.73	1.49	1.40	1.32
20°C	TC	7.56	6.00	4.86	4.56	4.20
	Input	2.20	1.86	1.64	1.51	1.42
27°C	TC	7.08	5.64	4.56	4.44	3.96
	Input	2.33	2.01	1.77	1.64	1.53

Remark:

TC : Total capacity ; kW

SC: Sensible heat capacity ; kW

Input: Input power ; kW

5.2 SIB-60TAY

Cooling

Cooling		Outdoor conditions (DB)				
Indoor Conditions	(kW)	18°C	21°C	28°C	35°C	43°C
21/15°C DB/WB	TC	7.53	7.31	6.96	6.60	6.32
	SC	5.49	5.41	5.36	5.28	5.31
	Input	1.94	2.01	2.18	2.28	2.35
24/17°C DB/WB	TC	7.74	7.53	7.17	6.82	6.39
	SC	5.73	5.64	5.59	5.52	5.37
	Input	2.06	2.13	2.28	2.37	2.50
27/19°C DB/WB	TC	7.88	7.67	7.31	7.10	6.60
	SC	5.75	5.67	5.63	5.54	5.41
	Input	2.11	2.18	2.30	2.42	2.54
32/23°C DB/WB	TC	8.09	7.81	7.53	7.38	6.82
	SC	6.80	6.64	6.55	6.50	6.34
	Input	2.20	2.28	2.37	2.54	2.64

Heating

Heating		Outdoor conditions				
Indoor Conditions (DB)	(kW)	24/18°C DB/WB	7/6°C DB/WB	2/1°C DB/WB	-5/-6°C DB/WB	-7/-8°C DB/WB
15°C	TC	9.88	7.98	6.54	5.93	5.55
	Input	2.61	2.25	1.93	1.81	1.71
20°C	TC	9.58	7.60	6.16	5.78	5.32
	Input	2.85	2.42	2.13	1.96	1.84
27°C	TC	8.97	7.14	5.78	5.62	5.02
	Input	3.02	2.61	2.29	2.13	1.98

Remark:

TC : Total capacity ; kW

SC: Sensible heat capacity ; kW

Input: Input power ; kW

5.3 SIB-100TAY

Cooling

Cooling		Outdoor conditions (DB)				
Indoor Conditions	(kW)	18°C	21°C	28°C	35°C	43°C
21/15°C DB/WB	TC	11.13	10.82	10.29	9.77	9.35
	SC	8.12	8.00	7.92	7.81	7.85
	Input	3.45	3.57	3.88	4.05	4.18
24/17°C DB/WB	TC	11.45	11.13	10.61	10.08	9.45
	SC	8.47	8.35	8.27	8.16	7.94
	Input	3.66	3.79	4.05	4.22	4.44
27/19°C DB/WB	TC	11.66	11.34	10.82	10.50	9.77
	SC	8.51	8.39	8.33	8.19	8.01
	Input	3.75	3.88	4.09	4.31	4.52
32/23°C DB/WB	TC	11.97	11.55	11.13	10.92	10.08
	SC	10.05	9.82	9.68	9.61	9.37
	Input	3.92	4.05	4.22	4.52	4.69

Heating

Heating		Outdoor conditions				
Indoor Conditions (DB)	(kW)	24/18°C DB/WB	7/6°C DB/WB	2/1°C DB/WB	-5/-6°C DB/WB	-7/-8°C DB/WB
15°C	TC	15.60	12.60	10.32	9.36	8.76
	Input	4.35	3.75	3.22	3.02	2.86
20°C	TC	15.12	12.00	9.72	9.12	8.40
	Input	4.75	4.03	3.55	3.26	3.06
27°C	TC	14.16	11.28	9.12	8.88	7.92
	Input	5.04	4.35	3.83	3.55	3.30

Remark:

TC : Total capacity ; kW

SC: Sensible heat capacity ; kW

Input: Input power ; kW

5.4 SIB-140TAY

Cooling

Cooling		Outdoor conditions (DB)				
Indoor Conditions	(kW)	18°C	21°C	28°C	35°C	43°C
21/15°C DB/WB	TC	14.84	14.42	13.72	13.02	12.46
	SC	10.83	10.67	10.56	10.42	10.47
	Input	4.15	4.31	4.67	4.88	5.03
24/17°C DB/WB	TC	15.26	14.84	14.14	13.44	12.60
	SC	11.29	11.13	11.03	10.89	10.58
	Input	4.41	4.57	4.88	5.09	5.35
27/19°C DB/WB	TC	15.54	15.12	14.42	14.00	13.02
	SC	11.34	11.19	11.10	10.92	10.68
	Input	4.52	4.67	4.93	5.19	5.45
32/23°C DB/WB	TC	15.96	15.40	14.84	14.56	13.44
	SC	13.41	13.09	12.91	12.81	12.50
	Input	4.72	4.88	5.09	5.45	5.66

Heating

Heating		Outdoor conditions				
Indoor Conditions (DB)	(kW)	24/18°C DB/WB	7/6°C DB/WB	2/1°C DB/WB	-5/-6°C DB/WB	-7/-8°C DB/WB
15°C	TC	19.50	15.75	12.90	11.70	10.95
	Input	5.44	4.68	4.03	3.77	3.57
20°C	TC	18.90	15.00	12.15	11.40	10.50
	Input	5.94	5.03	4.43	4.08	3.83
27°C	TC	17.70	14.10	11.40	11.10	9.90
	Input	6.29	5.44	4.78	4.43	4.13

Remark:

TC : Total capacity ; kW

SC: Sensible heat capacity ; kW

Input: Input power ; kW

5.5 SIB-200TAY

Cooling

Cooling		Outdoor conditions (DB)				
Indoor Conditions	(kW)	18°C	21°C	28°C	35°C	43°C
21/15°C DB/WB	TC	16.96	16.48	15.68	14.88	14.24
	SC	12.38	12.20	12.07	11.90	11.96
	Input	5.25	5.45	5.91	6.17	6.37
24/17°C DB/WB	TC	17.44	16.96	16.16	15.36	14.40
	SC	12.91	12.72	12.60	12.44	12.10
	Input	5.58	5.77	6.17	6.43	6.76
27/19°C DB/WB	TC	17.76	17.28	16.48	16.00	14.88
	SC	12.96	12.79	12.69	12.48	12.20
	Input	5.71	5.91	6.23	6.56	6.89
32/23°C DB/WB	TC	18.24	17.60	16.96	16.64	15.36
	SC	15.32	14.96	14.76	14.64	14.28
	Input	5.97	6.17	6.43	6.89	7.15

Heating

Heating		Outdoor conditions				
Indoor Conditions (DB)	(kW)	24/18°C DB/WB	7/6°C DB/WB	2/1°C DB/WB	-5/-6°C DB/WB	-7/-8°C DB/WB
15°C	TC	24.70	19.95	16.34	14.82	13.87
	Input	6.75	5.81	5.00	4.68	4.43
20°C	TC	23.94	19.00	15.39	14.44	13.30
	Input	7.37	6.25	5.50	5.06	4.75
27°C	TC	22.42	17.86	14.44	14.06	12.54
	Input	7.81	6.75	5.93	5.50	5.12

Remark:

TC : Total capacity ; kW

SC: Sensible heat capacity ; kW

Input: Input power ; kW

6. Wiring Diagrams

SIB-50TAV

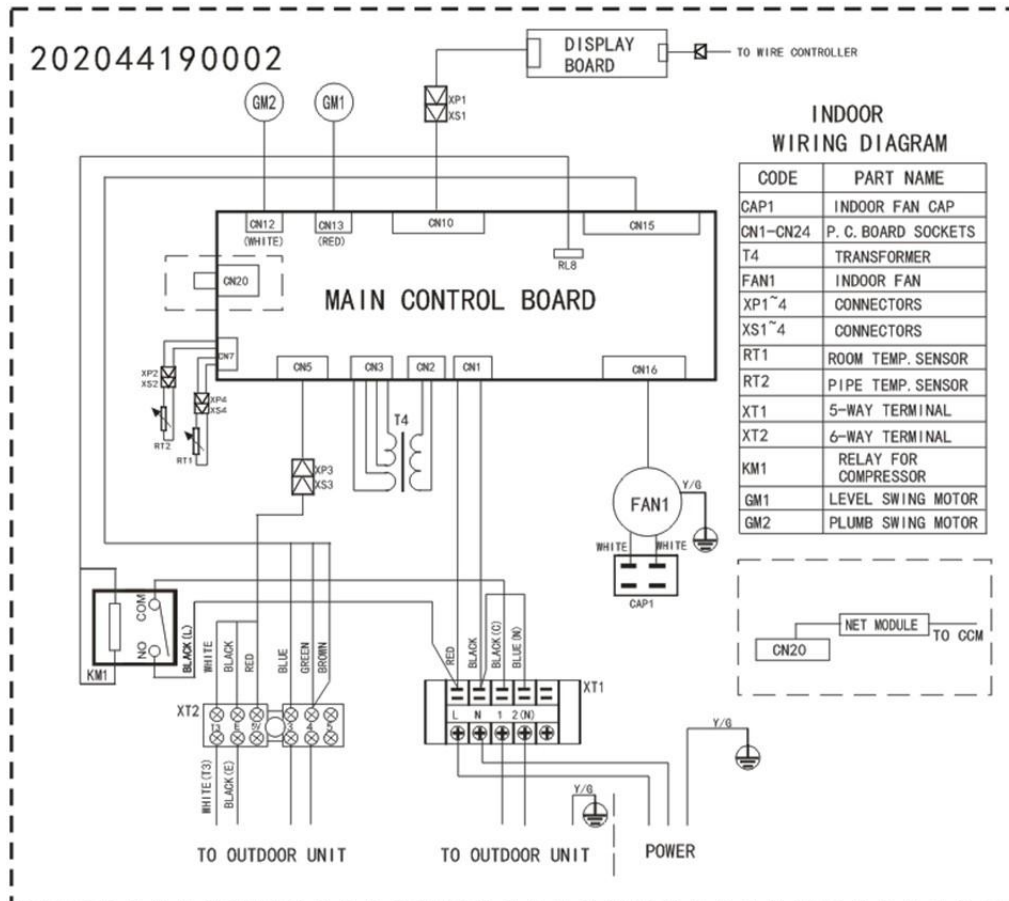

SIB-60TAV

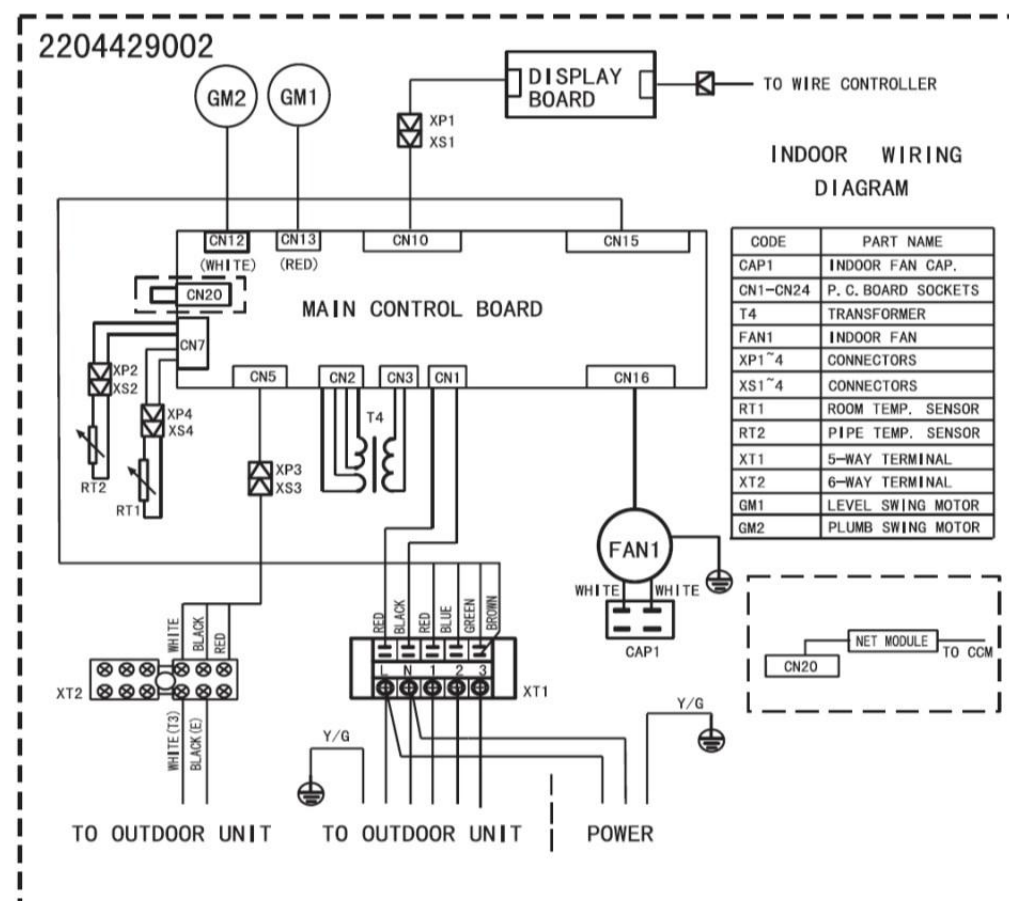

SIB-100TAY

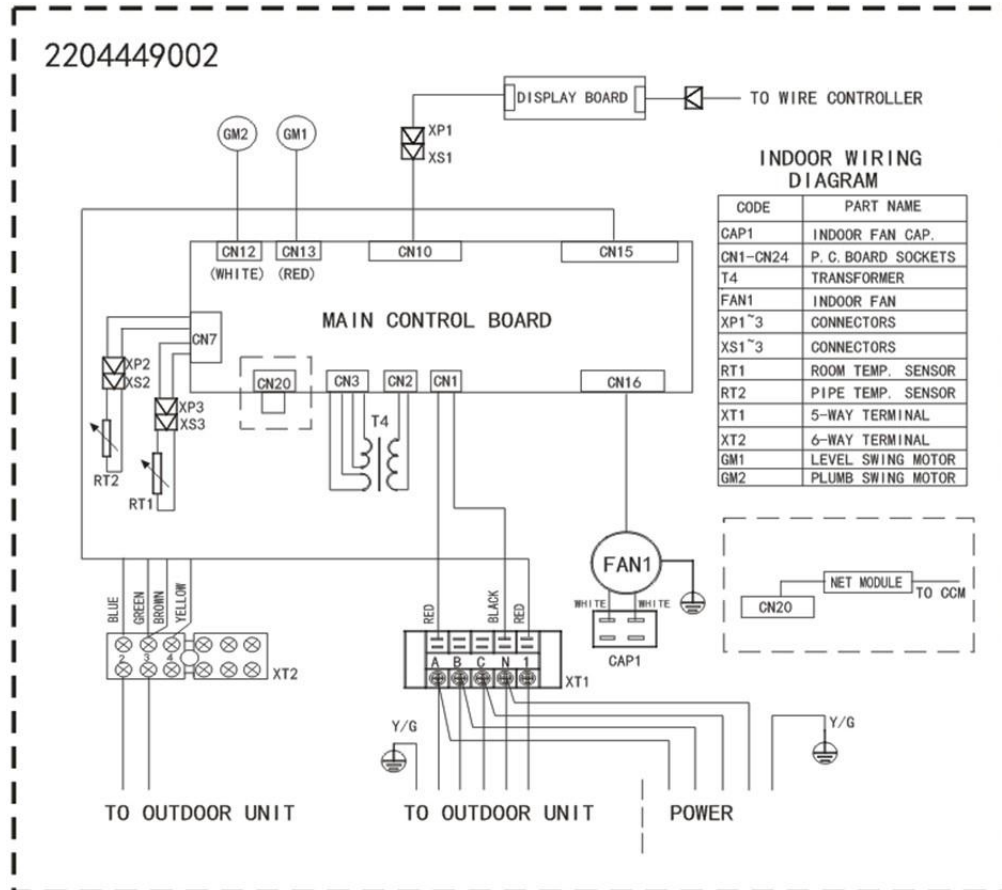

SIB-140TAY

SIB-200TAY

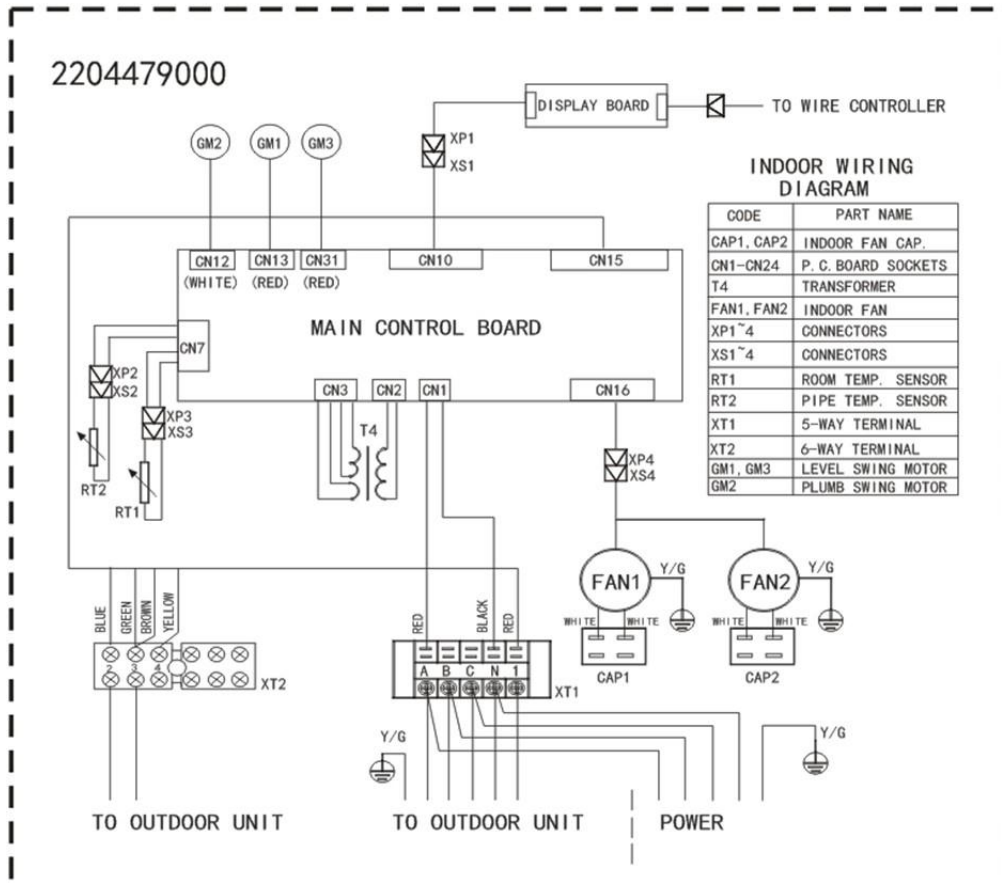

7. Air Velocity and Temperature Distributions Discharge angle 60° (CEILING)

Airflow velocity

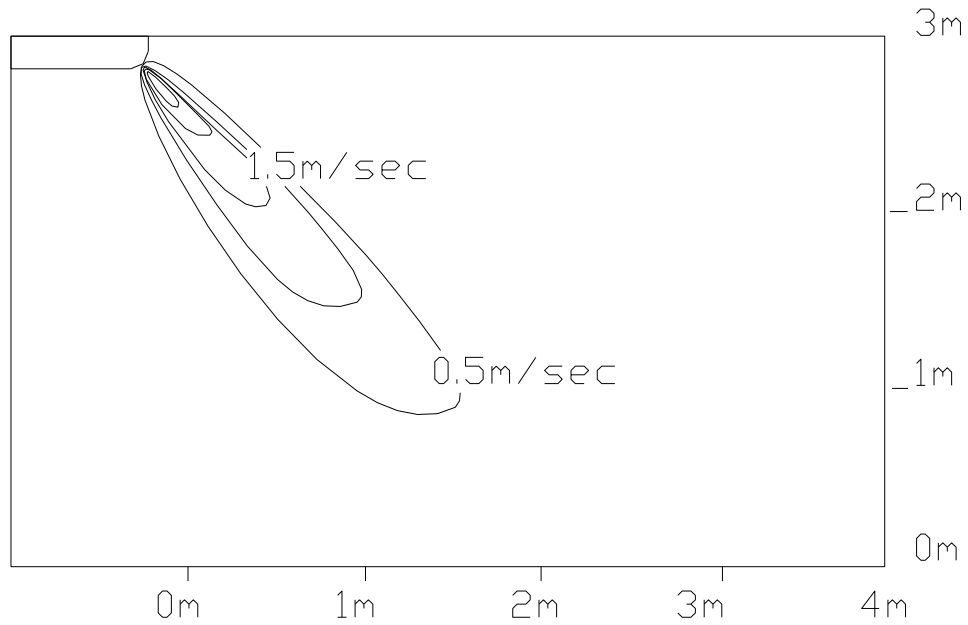

Temperature

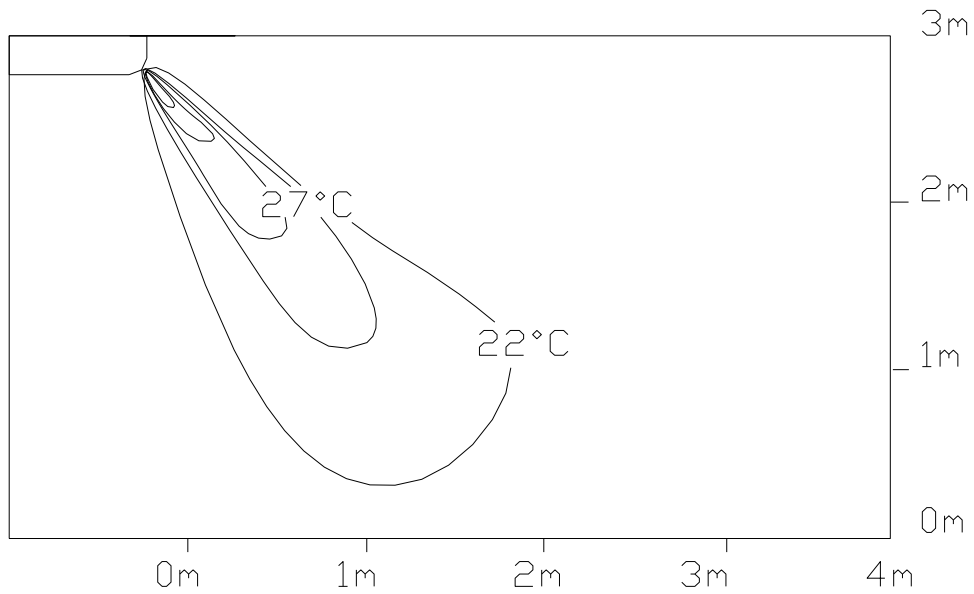

Discharge angle 60°(FLOOR)

Temperature

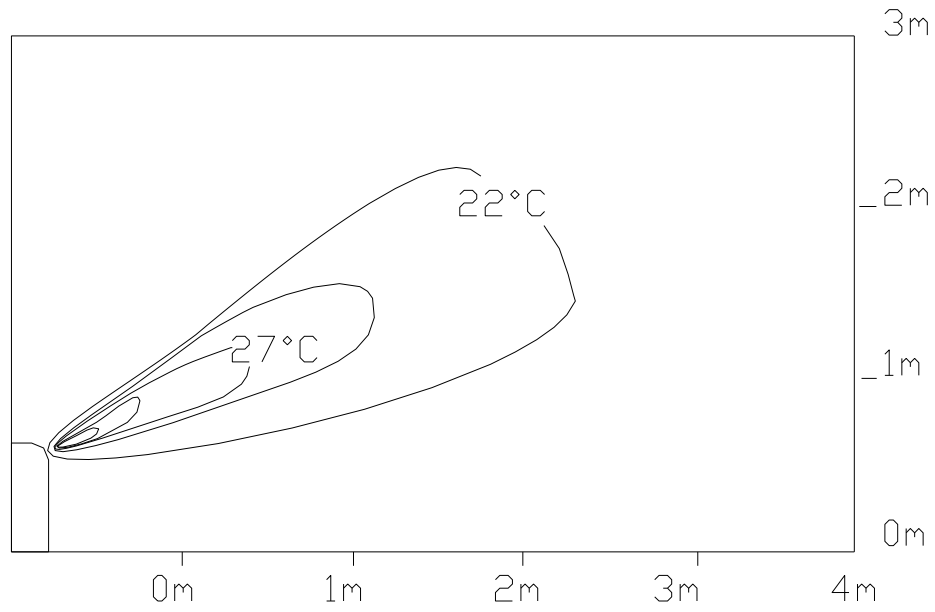

Airflow velocity

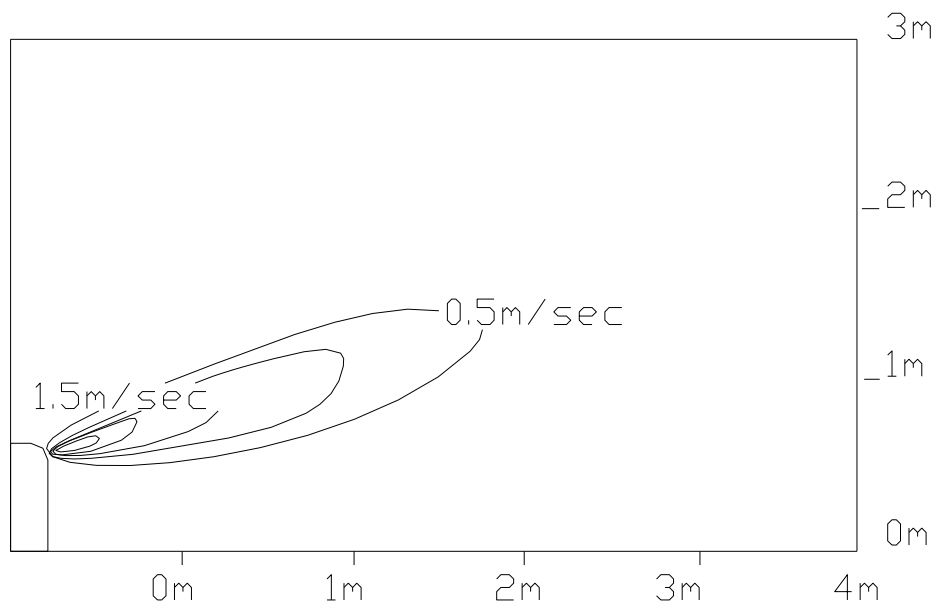

8. Electric Characteristics

Model	Indoor Units				Power Supply
	Hz	Voltage	Min.	Max.	MFA
SIB-50TAV	50	220-240V	198V	254V	16
SIB-60TAV	50	220-240V	198V	254V	25
SIB-100TAY	50	380-415V	342V	418V	20
SIB-140TAY	50	380-415V	342V	418V	20
SIB-200TAY	50	380-415V	342V	418V	20

Remark:

MFA: Max. Fuse Amps. (A)

9. Sound Levels

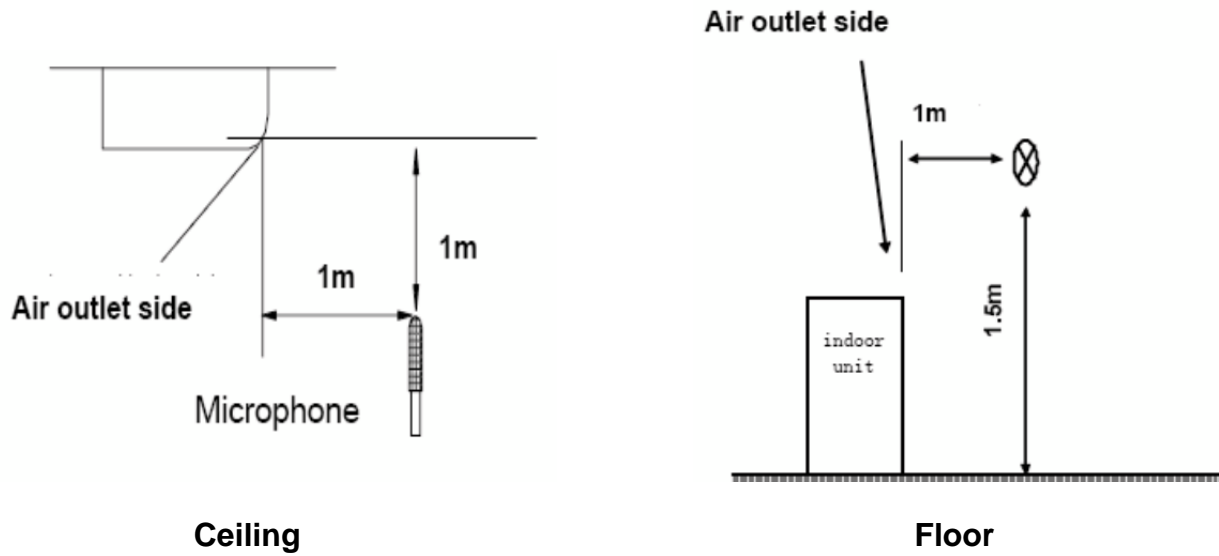

Model	Noise level dB(A)		
	H	M	L
SIB-50TAV	43	41	38
SIB-60TAV	45	43	40
SIB-100TAY	45	43	40
SIB-140TAY	50	47	45
SIB-200TAY	50	49	47

10. The Specification of Power

Cooling & Heating

Type		18000Btu/h	24000Btu/h	36000-60000Btu/h
Power	Phase	1-phase	1-phase	3-phase
	Frequency and Voltage	220-240V, 50Hz	220-240V, 50Hz	380-415V, 50Hz
Circuit Breaker/ Fuse (A)		20/16	40/25	40/20
Indoor Unit Power Wiring (mm ²)		3×2.5	3×2.5	5×2.5
Indoor/Outdoor Connecting Wiring (mm ²)	Ground Wiring	2.5	2.5	2.5
	Outdoor Unit Power Wiring	—————	3×2.5	5×2.5
	Strong Electric Signal	5×2.5	3×2.5	3×1.0
	Weak Electric Signal	2-core shield wire 2×0.75 mm ²	2-core shield wire 2×0.75 mm ²	—————

11. Field Wiring

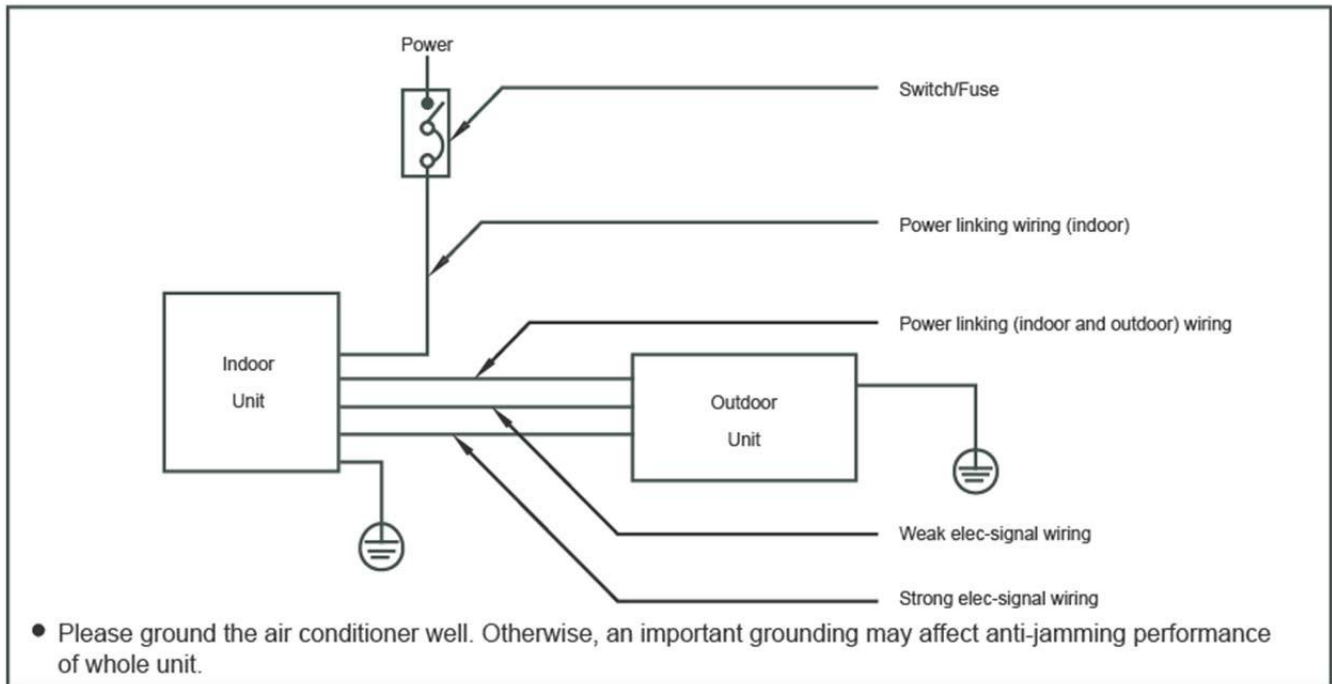

A

CAUTION

A disconnection device having an air gap contact separation in all active conductors should be incorporated in the fixed wiring according to the National Wiring Regulation.

When wiring, please choose the corresponding chart, or it may cause damage. The signs of the  indoor terminal block in the some of following figures may be replaced by L N L1 N1.

SIB-50TAV

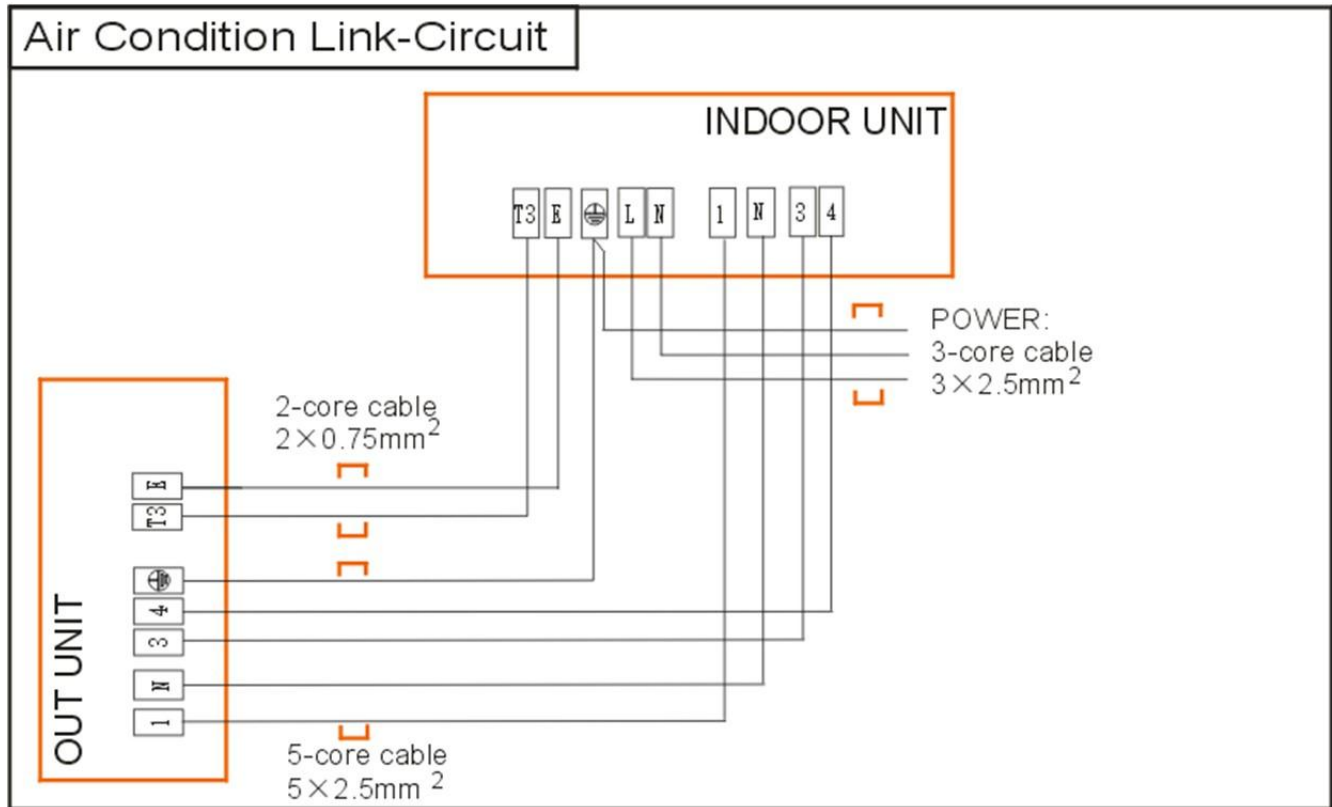

SIB-60TAV

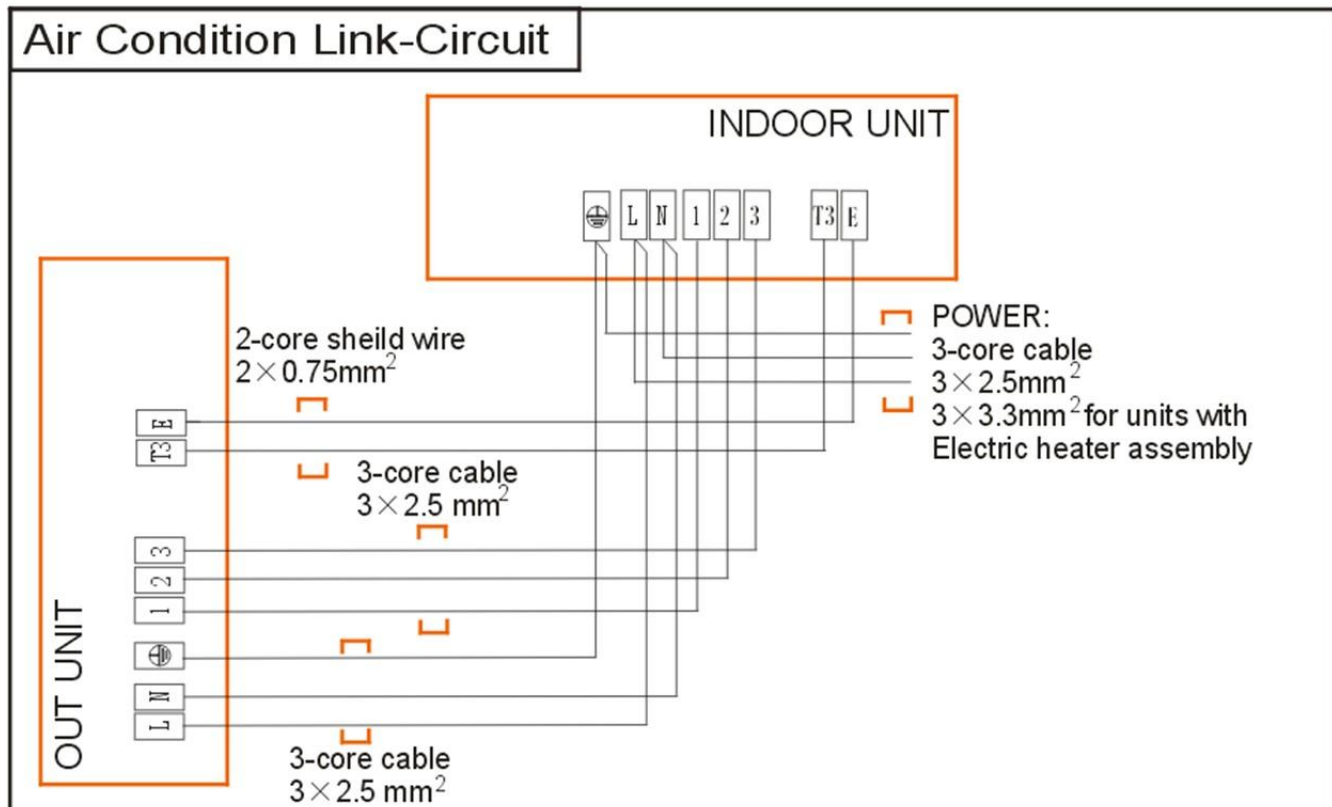

SIB-100TAY SIB-140TAY SIB-200TAY

Air Condition Link-Circuit

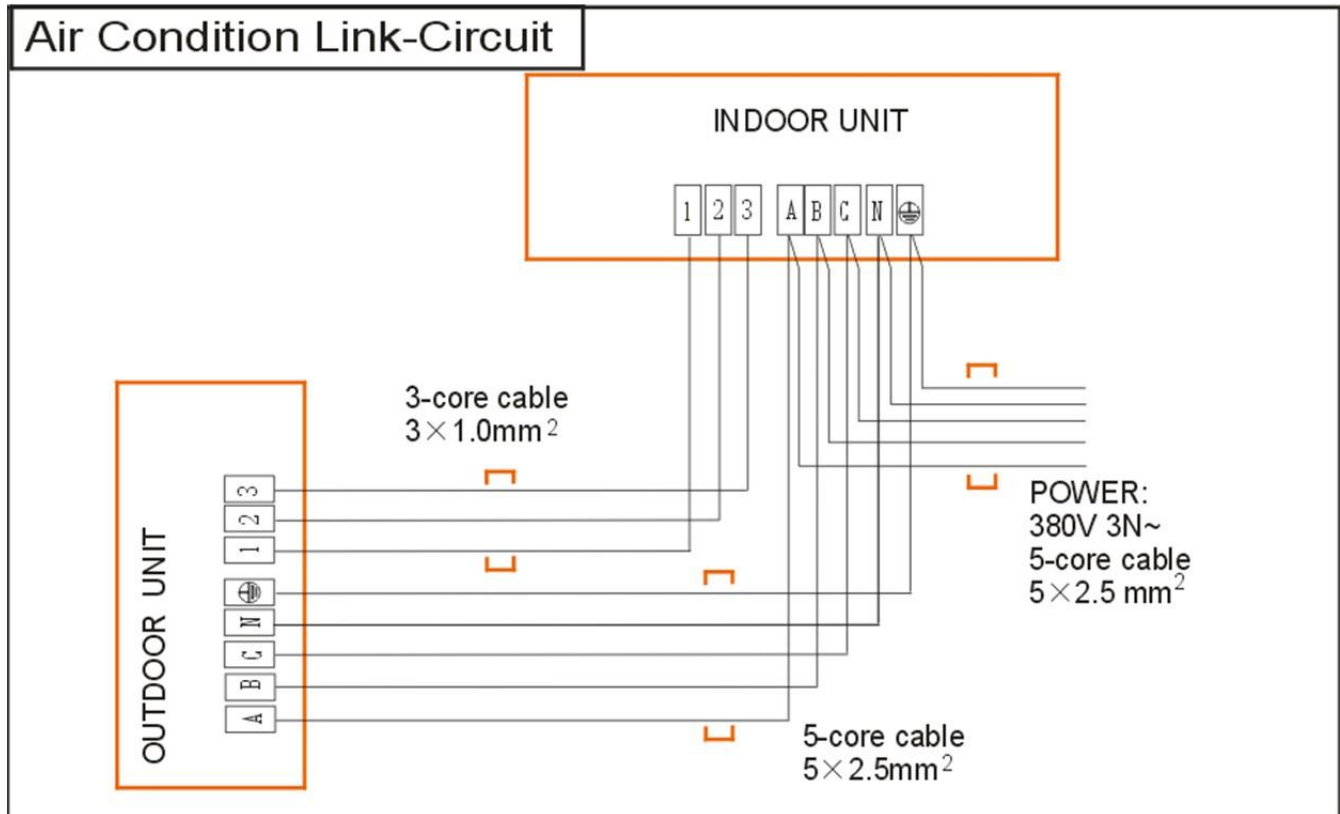

High Static Pressure Duct Type

1. Features	64
2. Specifications	65
3. Dimensions	67
4. Service Space	69
5. Wiring Diagrams	70
6. Capacity Tables.....	72
7. Static Pressure.....	76
8. Electric Characteristics.....	77
9. Sound Levels	78
10. The Specification of Power.....	79
11. Field Wiring	80

1. Features

- (1) In case the ceiling is super-high.
--Blowing pressure of Indoor unit can reach 160Pa. The air conditioner delivers cold wind to every indoor corner even the ceiling is super-high.
- (2) Multi-blowing outlets satisfy the fitment's needs.
- (3) Fresh air can be supplied, which improves the Indoor air quality greatly.
- (4) Wired control and group control are available.
- (5) High capacity of cooling/heating, efficient, and energy-saving.
- (6) Innovative air supply, which provides homogeneous conditioning of the room temperature.
- (7) It can be used in office, hospital, commercial place and home, the air conditioner will create the comfortable and elegance environment for you.
- (8) Compact design: Smaller dimension and larger stuffing capacity.
- (9) Universal outdoor unit design.
- (10) Flange is standard design to connect the air duct.
- (11) Filter is standard design.

2. Specifications

Model			SIB-60DAV	SIB-100DAY
Power supply		V- Ph-Hz	220~240-1-50	380~415-3-50
Cooling	Capacity	Btu/h	24000	36000
	Input	W	2500	3992
	EER	W/W	2.84	2.63
Heating	Capacity	Btu/h	26000	40000
	Input	W	2360	3934
	COP	W/W	3.23	3.05
Indoor fan motor	Model		YDK200-4F	YDK200-4F
	Qty		1	1
	Input	W	500/460/345	500/460/345
	Capacitor	uF/ V	15uF/370-450V	15uF/370-450V
	Speed (Hi/Mid/Lo)	r/min	1060/980/820	1060/980/820
Indoor coil	Number of rows		3	3
	Tube pitch(a)×row pitch(b)	mm	25.4 x22	25.4 x22
	Fin spacing	mm	1.6	1.6
	Fin type		Hydrophilic aluminium	Hydrophilic aluminium
	Tube outside diameter .and type	mm	Φ9.5,inner grooved tube	Φ9.5,inner grooved tube
	Coil length×height×width	mm	700x356x66	700x356x66
	Number of circuits		7	7
Indoor air flow (Hi/Med/Lo)		m ³ /h	1800/1670/1450	2400/2200/2000
Indoor external static pressure (Hi)		Pa	100	150
Indoor noise level (Hi/Med/Lo)		dB(A)	46/45/44	56/54/50
Indoor unit	Dimension (W×D×H)	mm	856x691x400	856x691x400
	Packing (W×D×H)	mm	1090x768x440	1090x768x440
	Net/Gross weight	kg	47/53.5	47/53.5
Design pressure		MPa	4.2/1.5	4.2/1.5
Drainage water pipe dia			ODØ25	ODØ25
Refrigerant piping	Liquid side/ Gas side	mm	Ø12.7/Ø19	Ø12.7/Ø19
Controller			SAR-24	SAR-24
Operation temperature		°C	17-30	17-30

Notes:

- Nominal cooling capacities are based on the following conditions:
Indoor temp: 27°CDB, 19°CWB; Outdoor temp: 35°CDB; Equivalent ref. piping: 7.5m (horizontal)
- Nominal heating capacities are based on the following conditions:
Indoor temp: 20°CDB; Outdoor temp: 7°CDB, 6°CWB; Equivalent ref. piping: 7.5m (horizontal)
- Actual noise level may differ, depending on the room structure, etc, since these noise values are from an anechoic room.

Model			SIB-140DAY	SIB-200DAY
Power supply		V- Ph-Hz	380~420-3-50	380~420-3-50
Cooling	Capacity	Btu/h	48000	60000
	Input	W	5323	6084
	EER	W/W	2.63	2.89
Heating	Capacity	Btu/h	52000	65000
	Input	W	5000	6376
	COP	W/W	3.00	2.99
Indoor fan motor	Model		YDK360-4F	YSK400-4C
	Qty		1	1
	Input	W	630/570/435	930/740/592
	Capacitor	uF/ V	15uF/370-450V	15uF/370-450V
	Speed (Hi/Mid/Lo)	r/min	1210/1135/960	1080/920/790
Indoor coil	Number of rows		4	3
	Tube pitch(a)×row pitch(b)	mm	25.4x22	25.4 x22
	Fin spacing	mm	1.6	1.6
	Fin type		Hydrophilic aluminium	Hydrophilic aluminium
	Tube outside diameter .and type	mm	Φ9.5,inner groove tube	Φ9.5,inner grooved tube
	Coil length×height×width	mm	700x356x88	996x356x66
	Number of circuits		7	7
Indoor air flow (Hi/Med/Lo)		m ³ /h	3900/3700/3000	4000/3750/3100
Indoor external static pressure (Hi)		Pa	160	160
Indoor noise level (Hi/Med/Lo)		dB(A)	58/56/51	57/53/50
Indoor unit	Dimension (W×D×H)	mm	856x691x400	1200x691x400
	Packing (W×D×H)	mm	1090x768x440	1436x768x440
	Net/Gross weight	kg	52/57	63/70
Design pressure		MPa	4.2/1.5	4.2/1.5
Drainage water pipe dia			ODØ25	ODØ25
Refrigerant piping	Liquid side/ Gas side	mm	Ø12.7/Ø19	Ø12.7/Ø19
Controller			SAR-24	SAR-24
Operation temperature		°C	17-30	17-30

Notes:

- Nominal cooling capacities are based on the following conditions:
Indoor temp: 27°CDB, 19°CWB; Outdoor temp: 35°CDB; Equivalent ref. piping: 7.5m (horizontal)
- Nominal heating capacities are based on the following conditions:
Indoor temp: 20°CDB; Outdoor temp: 7°CDB, 6°CWB; Equivalent ref. piping: 7.5m (horizontal)
- Actual noise level may differ, depending on the room structure, etc, since these noise values are from an anechoic room.

3. Dimensions

MODEL 24~36

Unit: mm

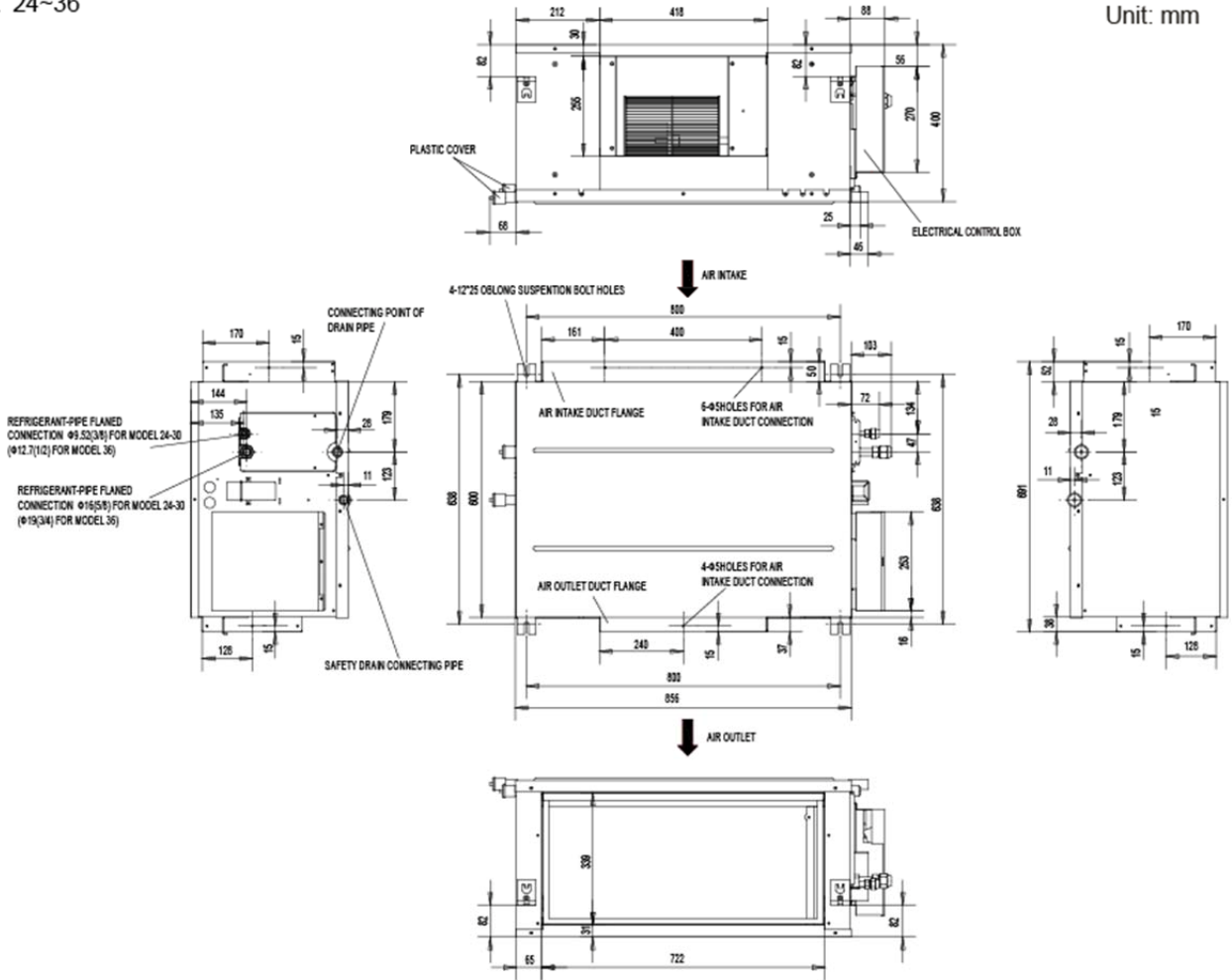

MODEL 42~60

Unit: mm

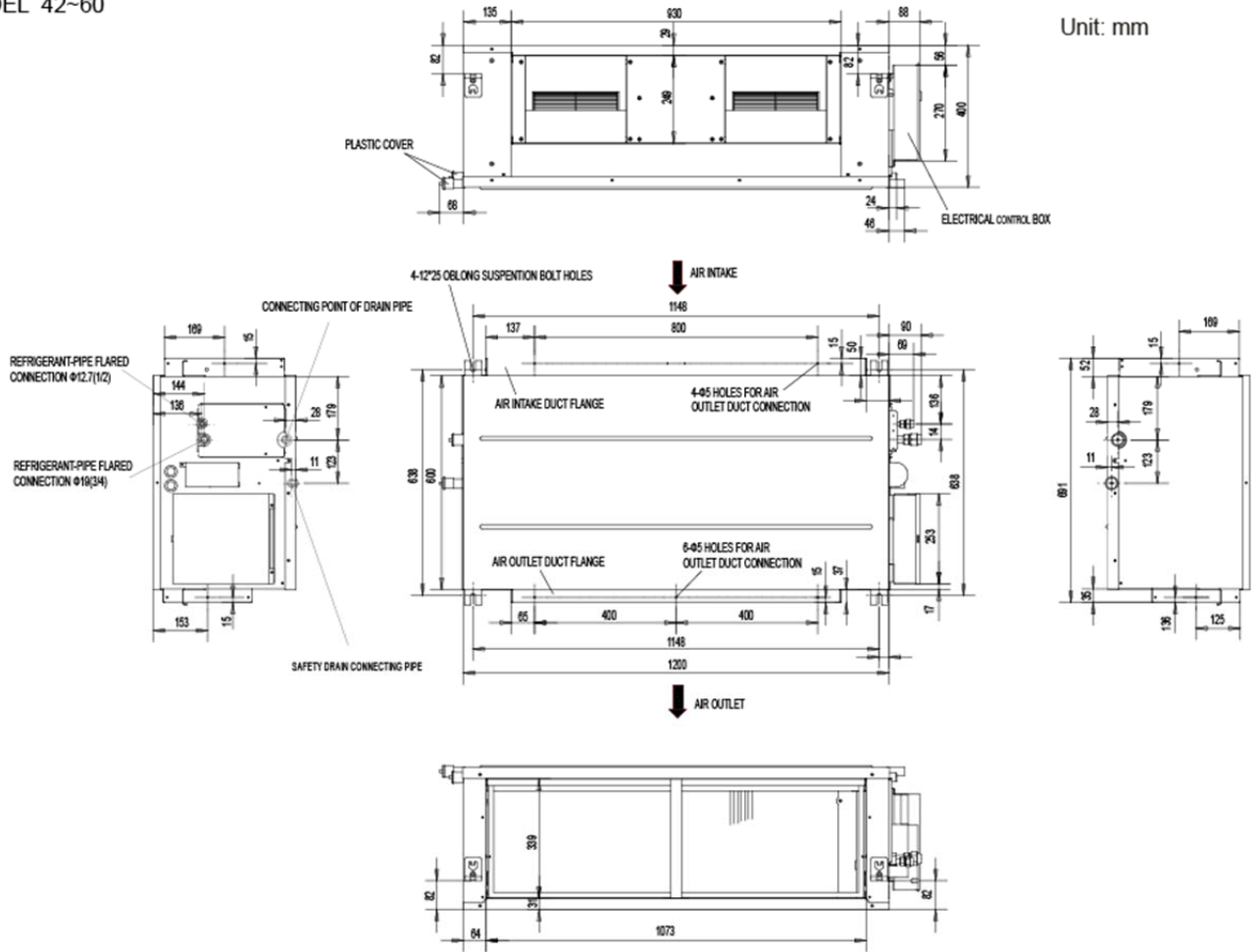

4. Service Space

Ensure enough space required for installation and maintenance.

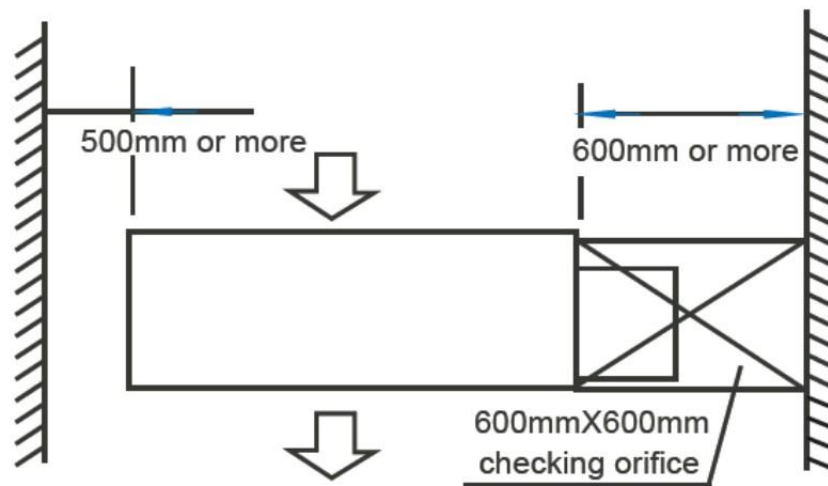

5. Wiring Diagrams

5.1 SIB-60DAY

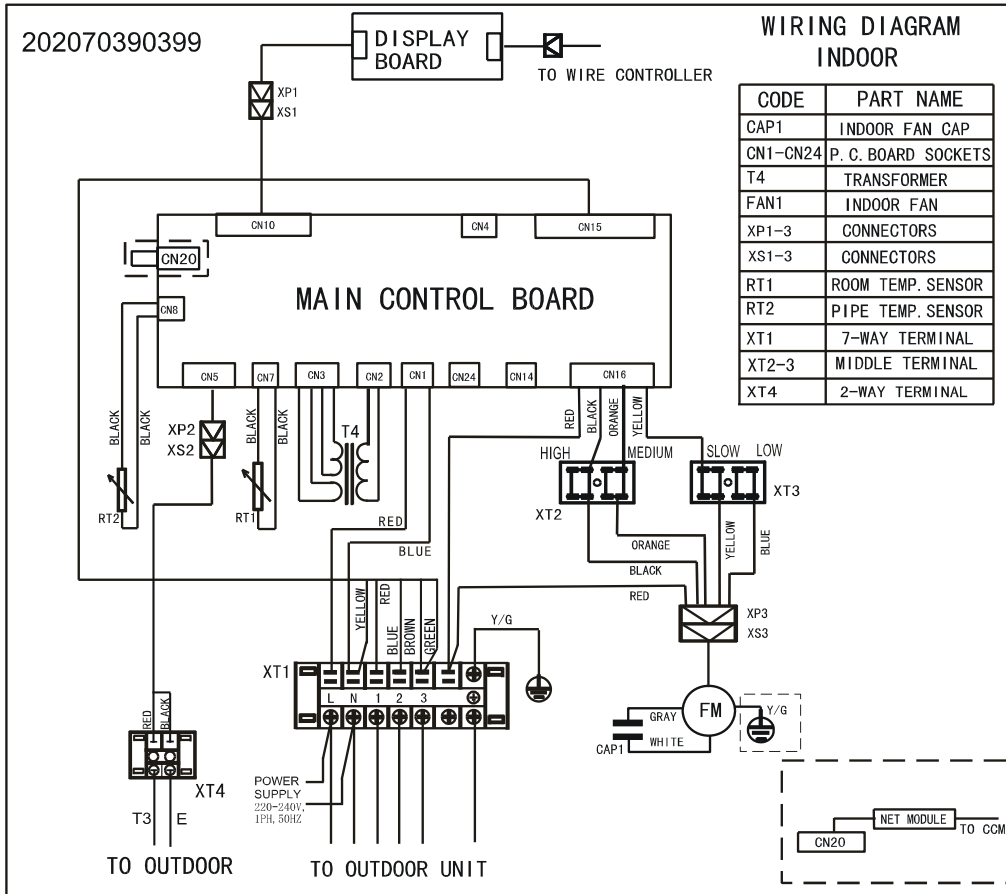

5.2 SIB-100DAY

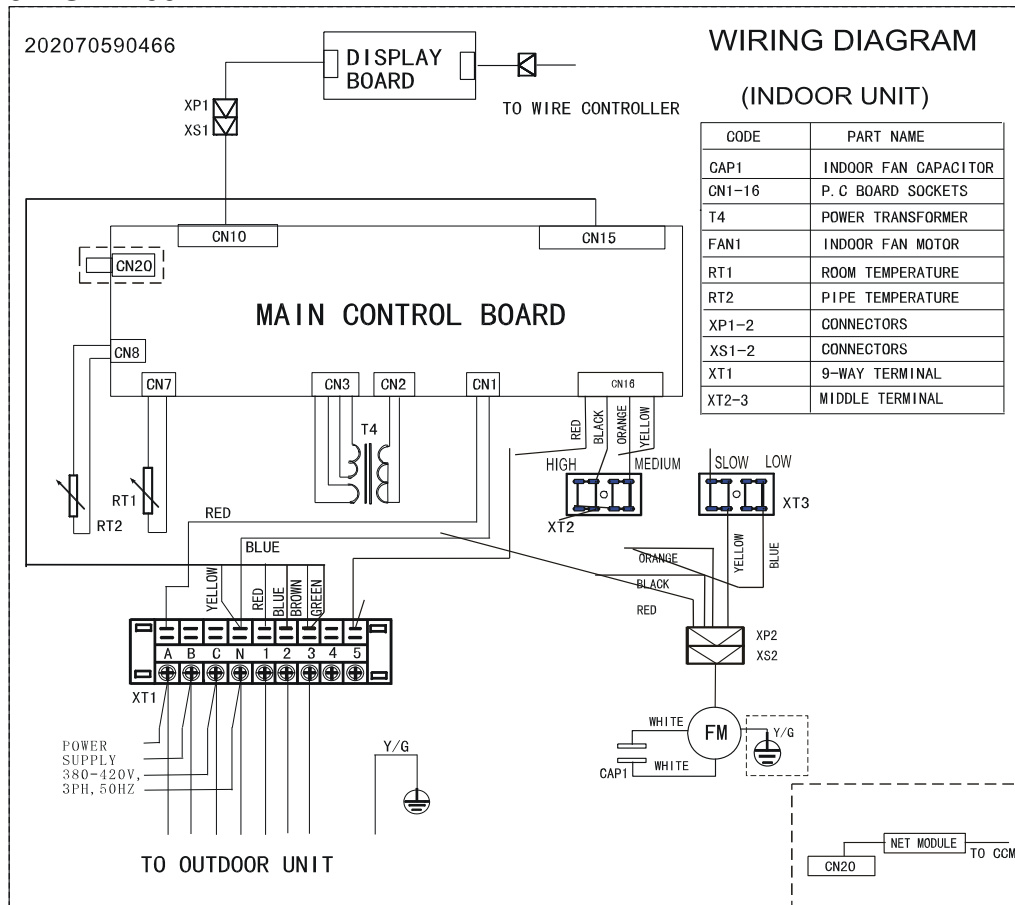

5.3 SIB-140DAY SIB-200DAY

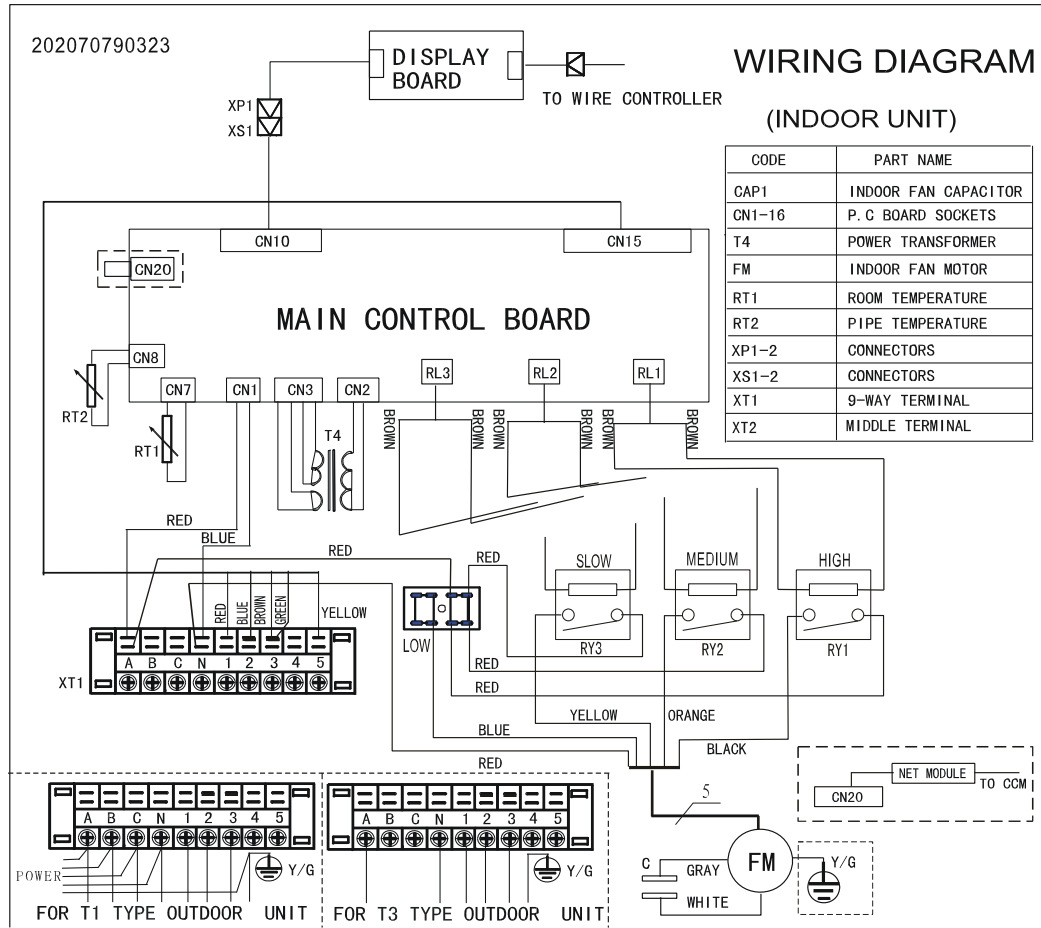

CODE	PART NAME
CAP1	INDOOR FAN CAPACITOR
CN1-16	P. C BOARD SOCKETS
T4	POWER TRANSFORMER
FM	INDOOR FAN MOTOR
RT1	ROOM TEMPERATURE
RT2	PIPE TEMPERATURE
XP1-2	CONNECTORS
XS1-2	CONNECTORS
XT1	9-WAY TERMINAL
XT2	MIDDLE TERMINAL

6. Capacity Tables

SIB-60DAV

Cooling

Cooling		Outdoor conditions (DB)				
Indoor Conditions	(kW)	18°C	21°C	28°C	35°C	43°C
21/15°C DB/WB	TC	7.53	7.31	6.96	6.60	6.32
	SC	5.49	5.41	5.36	5.28	5.31
	Input	2.00	2.08	2.25	2.35	2.43
24/17°C DB/WB	TC	7.74	7.53	7.17	6.82	6.39
	SC	5.73	5.64	5.59	5.52	5.37
	Input	2.13	2.20	2.35	2.45	2.58
27/19°C DB/WB	TC	7.88	7.67	7.31	7.10	6.60
	SC	5.75	5.67	5.63	5.54	5.41
	Input	2.18	2.25	2.38	2.50	2.63
32/23°C DB/WB	TC	8.09	7.81	7.53	7.38	6.82
	SC	6.80	6.64	6.55	6.50	6.34
	Input	2.28	2.35	2.45	2.63	2.73

Heating

Heating		Outdoor conditions				
Indoor Conditions (DB)	(kW)	24/18°C DB/WB	7/6°C DB/WB	2/1°C DB/WB	-5/-6°C DB/WB	-7/-8°C DB/WB
15°C	TC	9.88	7.98	6.54	5.93	5.55
	Input	2.54	2.19	1.88	1.76	1.67
20°C	TC	9.58	7.60	6.16	5.78	5.32
	Input	2.78	2.35	2.07	1.91	1.79
27°C	TC	8.97	7.14	5.78	5.62	5.02
	Input	2.94	2.54	2.24	2.07	1.93

Remark:

TC : Total capacity ; kW

SC: Sensible heat capacity ; kW

Input: Input power ; kW

SIB-100DAY**Cooling**

Cooling		Outdoor conditions (DB)				
Indoor Conditions	(kW)	18°C	21°C	28°C	35°C	43°C
21/15°C DB/WB	TC	11.13	10.82	10.29	9.77	9.35
	SC	8.12	8.00	7.92	7.81	7.85
	Input	3.19	3.31	3.59	3.75	3.87
24/17°C DB/WB	TC	11.45	11.13	10.61	10.08	9.45
	SC	8.47	8.35	8.27	8.16	7.94
	Input	3.39	3.51	3.75	3.91	4.11
27/19°C DB/WB	TC	11.66	11.34	10.82	10.50	9.77
	SC	8.51	8.39	8.33	8.19	8.01
	Input	3.47	3.59	3.79	3.99	4.19
32/23°C DB/WB	TC	11.97	11.55	11.13	10.92	10.08
	SC	10.05	9.82	9.68	9.61	9.37
	Input	3.63	3.75	3.91	4.19	4.35

Heating

Heating		Outdoor conditions				
Indoor Conditions (DB)	(kW)	24/18°C DB/WB	7/6°C DB/WB	2/1°C DB/WB	-5/-6°C DB/WB	-7/-8°C DB/WB
15°C	TC	15.60	12.60	10.32	9.36	8.76
	Input	4.25	3.66	3.15	2.95	2.79
20°C	TC	15.12	12.00	9.72	9.12	8.40
	Input	4.64	3.93	3.46	3.19	2.99
27°C	TC	14.16	11.28	9.12	8.88	7.92
	Input	4.92	4.25	3.74	3.46	3.23

Remark:

TC : Total capacity ; kW

SC: Sensible heat capacity ; kW

Input: Input power ; kW

SIB-140DAY

Cooling

Cooling		Outdoor conditions (DB)				
Indoor Conditions	(kW)	18°C	21°C	28°C	35°C	43°C
21/15°C DB/WB	TC	14.84	14.42	13.72	13.02	12.46
	SC	10.83	10.67	10.56	10.42	10.47
	Input	4.26	4.42	4.79	5.00	5.16
24/17°C DB/WB	TC	15.26	14.84	14.14	13.44	12.60
	SC	11.29	11.13	11.03	10.89	10.58
	Input	4.52	4.68	5.00	5.22	5.48
27/19°C DB/WB	TC	15.54	15.12	14.42	14.00	13.02
	SC	11.34	11.19	11.10	10.92	10.68
	Input	4.63	4.79	5.06	5.32	5.59
32/23°C DB/WB	TC	15.96	15.40	14.84	14.56	13.44
	SC	13.41	13.09	12.91	12.81	12.50
	Input	4.84	5.00	5.22	5.59	5.80

Heating

Heating		Outdoor conditions				
Indoor Conditions (DB)	(kW)	24/18°C DB/WB	7/6°C DB/WB	2/1°C DB/WB	-5/-6°C DB/WB	-7/-8°C DB/WB
15°C	TC	19.50	15.75	12.90	11.70	10.95
	Input	5.40	4.65	4.00	3.75	3.55
20°C	TC	18.90	15.00	12.15	11.40	10.50
	Input	5.90	5.00	4.40	4.05	3.80
27°C	TC	17.70	14.10	11.40	11.10	9.90
	Input	6.25	5.40	4.75	4.40	4.10

Remark:

TC : Total capacity ; kW

SC: Sensible heat capacity ; kW

Input: Input power ; kW

SIB-200DAY

Cooling

Cooling		Outdoor conditions (DB)				
Indoor Conditions	(kW)	18°C	21°C	28°C	35°C	43°C
21/15°C DB/WB	TC	16.96	16.48	15.68	14.88	14.24
	SC	12.38	12.20	12.07	11.90	11.96
	Input	4.87	5.05	5.48	5.72	5.90
24/17°C DB/WB	TC	17.44	16.96	16.16	15.36	14.40
	SC	12.91	12.72	12.60	12.44	12.10
	Input	5.17	5.35	5.72	5.96	6.27
27/19°C DB/WB	TC	17.76	17.28	16.48	16.00	14.88
	SC	12.96	12.79	12.69	12.48	12.20
	Input	5.29	5.48	5.78	6.08	6.39
32/23°C DB/WB	TC	18.24	17.60	16.96	16.64	15.36
	SC	15.32	14.96	14.76	14.64	14.28
	Input	5.54	5.72	5.96	6.39	6.63

Heating

Heating		Outdoor conditions				
Indoor Conditions (DB)	(kW)	24/18°C DB/WB	7/6°C DB/WB	2/1°C DB/WB	-5/-6°C DB/WB	-7/-8°C DB/WB
15°C	TC	24.70	19.95	16.34	14.82	13.87
	Input	6.89	5.93	5.10	4.78	4.53
20°C	TC	23.94	19.00	15.39	14.44	13.30
	Input	7.52	6.38	5.61	5.16	4.85
27°C	TC	22.42	17.86	14.44	14.06	12.54
	Input	7.97	6.89	6.06	5.61	5.23

Remark:

TC : Total capacity ; kW

SC: Sensible heat capacity ; kW

Input: Input power ; kW

7. Static Pressure

MODEL 24

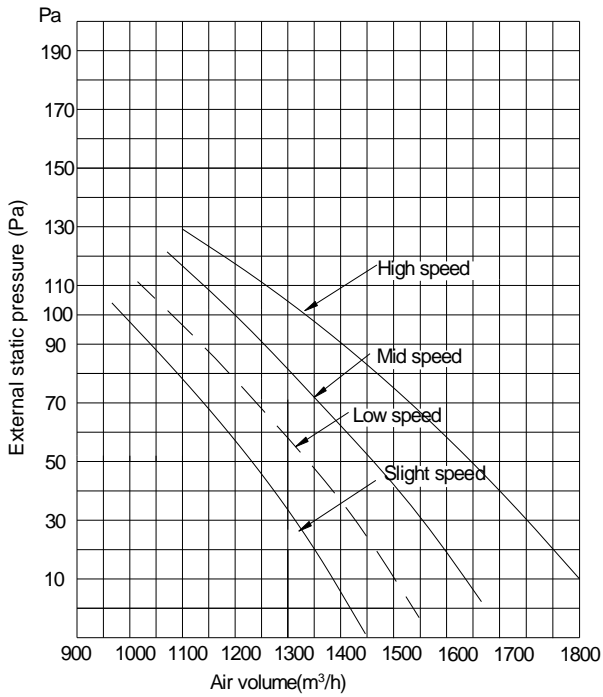

MODEL 36

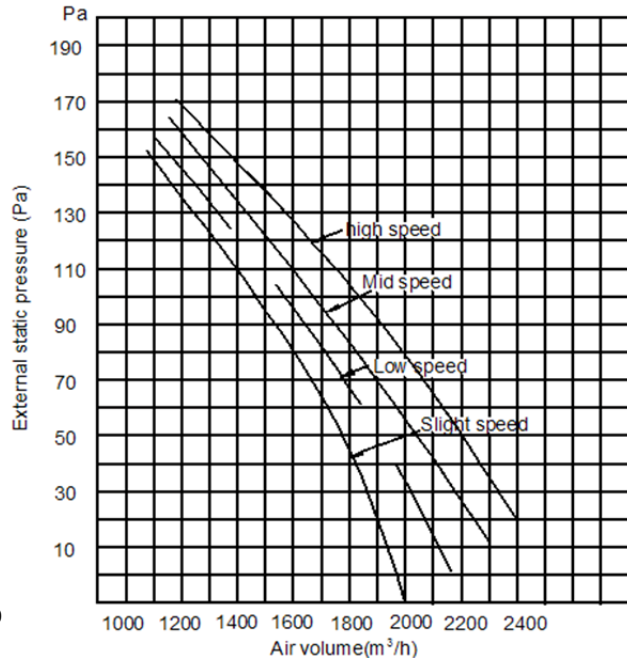

MODEL 48

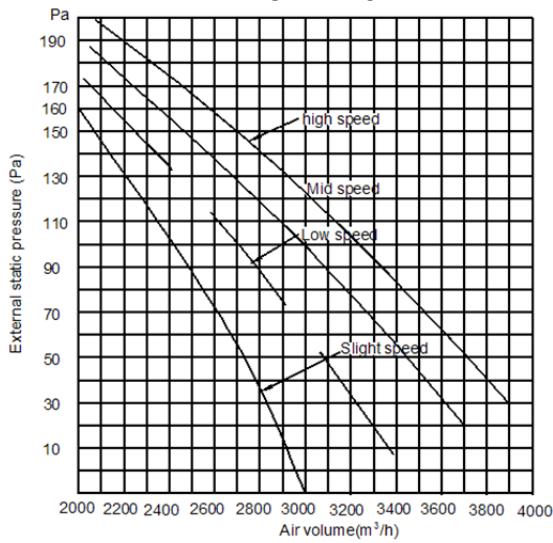

MODEL 60

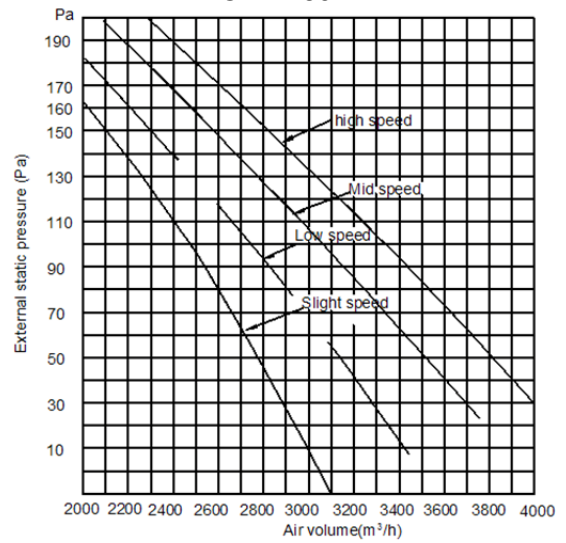

8. Electric Characteristics

Model	Indoor Units				Power Supply
	Hz	Voltage	Min.	Max.	MFA
SIB-60DAV	50	220-240V	198V	254V	15
SIB-100DAY	50	380-415V	342V	418V	25
SIB-140DAY	50	380-420V	342V	440V	25
SIB-200DAY	50	380-420V	342V	440V	25

Remark:

MFA: Max. Fuse Amps. (A)

9. Sound Levels

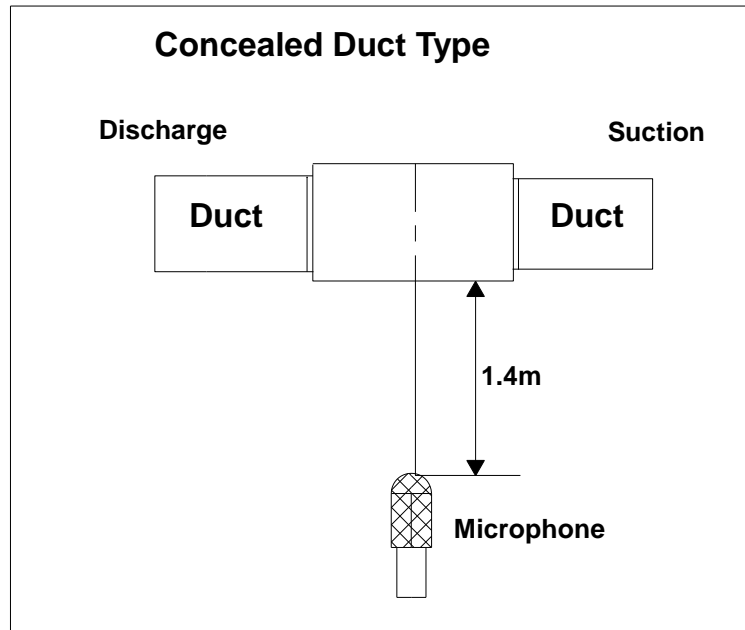

Model	Noise level dB(A)		
	H	M	L
SIB-60DAV	46	45	44
SIB-100DAY	56	54	50
SIB-140DAY	58	56	51
SIB-200DAY	57	53	50

10. The Specification of Power

MODEL		24	36-60
Power	Phase	1-phase	3-phase
	Frequency and Voltage	220-240V, 50Hz	380-415V~ 50Hz
Circuit Breaker/ Fuse (A)		30/15	40/25
Indoor Unit Power Wiring (mm ²)		3x2.5	5x2.5
Indoor/Outdoor Connecting Wiring (mm ²)	Ground Wiring	-----	-----
	Outdoor Unit Power Wiring	3x2.5	5x2.5
	Strong Electric Signal	3-core cable 3x1.5	3-core cable 3x2.5
	Weak Electric Signal	2-core shielded wire 2x0.75	-----

11. Field Wiring

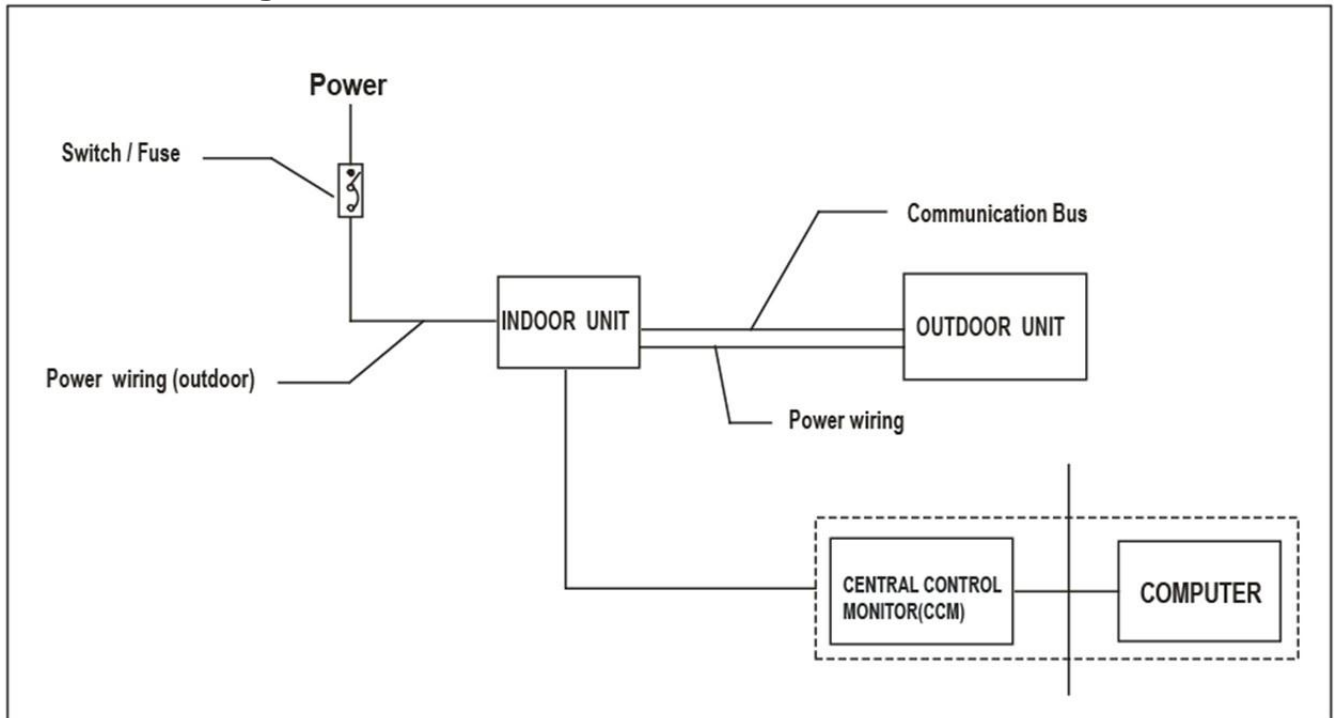

SIB-60DAV

Air Condition Link-Circuit

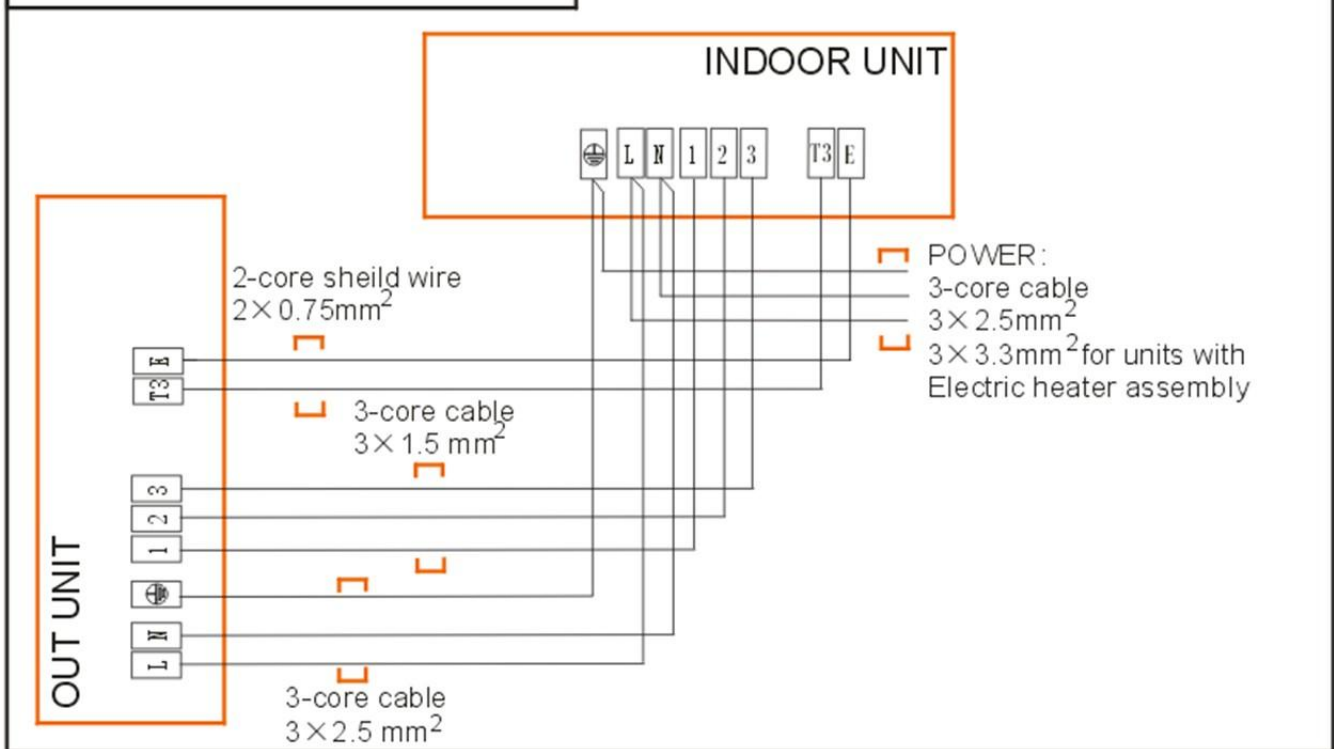

SIB-100DAY SIB-140DAY SIB-200DAY

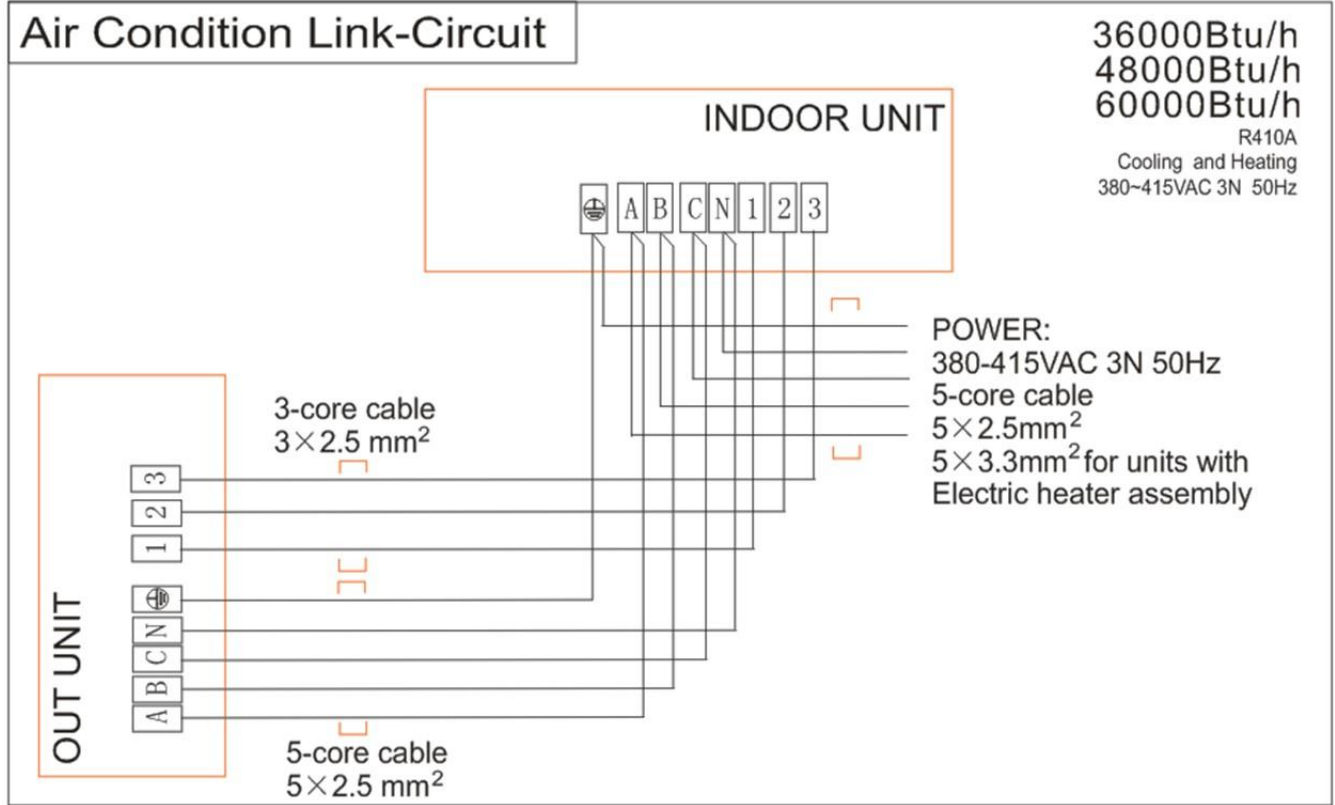

Part 3

Outdoor Units

1. Specifications.....	83
2. Dimensions.....	85
3. Service Space.....	87
4. Piping Diagrams.....	88
5. Wiring Diagrams.....	90
6. Electric Characteristics.....	93
7. Operation Limits.....	94
8. Sound Levels.....	95
9. Troubleshooting.....	96

1. Specifications

Model			SOB-50VA	SOB-60VA
Power supply		V-ph-Hz	220~240-1-50	220~240-1-50
Max. input consumption		W	2950	3450
Max. input current		A	15	18
Compressor	Model		PA225X2CS-4KU1	PA290X3CS-4MU1
	Type		Rotary	Rotary
	Brand		GMCC	GMCC
	Capacity	Btu/h	18493/18698	24498
	Input	W	1855/1940	2430
	Rated current(RLA)	A	8.7/8.7	11.4
	Locked rotor Amp(LRA)	A	36.8	61
	Thermal protector		Internal	Internal
	Capacitor	μF	50μF/440V-450V	50μF/440V-450V
Refrigerant oil	ml	ESTER OIL VG74 750	ESTER OIL VG74/950	
Outdoor fan motor	Model		YDK48-6H(A)	YDK100-6D
	Qty		1	1
	Input	W	110	168.7
	Capacitor	μF	3μF/450V	5μF/450V
	Speed	r/min	890	900
Outdoor coil	Number of rows		2	2
	Tube pitch(a)× row pitch(b)	mm	21x13.37	21x13.37
	Fin spacing	mm	1.4	1.4
	Fin type		Hydrophilic aluminum	Hydrophilic aluminum
	Tube outside dia.and type	mm	φ7, Inner grooved copper tube	φ7, Inner grooved copper tube
	Coil length × height × width	mm	658x546x26.74	785x651x26.74
	Number of circuits		4	4
Outdoor air flow		m ³ /h	2439	3200
Outdoor noise level (sound pressure)		dB(A)	54	55
Outdoor unit	Dimension(W×H×D)	mm	762x593x282	845×695×324
	Packing (W×H×D)	mm	887×645×355	965×755×395
	Net/Gross weight	kg	39/42	53/57
Refrigerant	Type		R410a	R410a
	Charged volume	g	1400	1900
Throttle type			Capillary	Capillary
Design pressure		MPa	4.2/1.5	4.2/1.5
Refrigerant piping	Liquid side/ Gas side	mm	φ6.4/φ12.7	φ9.5/φ15.9
	Max. pipe length	m	25	25
	Max. difference in level	m	15	15
Ambient temp.		°C	cooling:21~43; heating:-5~24	cooling: 21~43; heating:-5~24

- Notes:**
- Nominal cooling capacities are based on the following conditions:
Indoor temp: 27°CDB, 19°CWB; Outdoor temp: 35°CDB;
 - Nominal heating capacities are based on the following conditions:
Indoor temp: 20°CDB; Outdoor temp: 7°CDB, 6°CWB;
 - Actual noise level may differ, depending on the room structure, etc, since these noise values are from an anechoic room.

Model			SOB-100YA	SOB-140YA	SOB-200YA
Power supply		V-ph-H Z	380~415-3-50	380~415-3-50	380~415-3-50
Max. input consumption		W	4950	6300	7500
Max. input current		A	10	10.5	12.6
Compressor	Model		C-SBN303H8D	C-SBN373H8D	C-SBN453H8D
	Type		SCROLL	Scroll	Scroll
	Brand		SANYO	Sanyo	Sanyo
	Capacity	Btu/h	33438	48109	55956.8
	Input	W	3650	4750	5750
	Rated current(RLA)	A	6.58	8.22	9.77
	Locked rotor Amp(LRA)	A	48	66	67
	Thermal protector		Internal	Internal	Internal
	Capacitor	μF	--	--	---
Refrigerant oil	ml	FV68S/1700	FV68S,1700	FV68S, 1700	
Outdoor fan motor	Model		YDK190-6D(B)	YDK65-6/YDK65-6F	YDK65-6+YDK65-6F
	Qty		1	2	2
	Input	W	290	148+156	148+140
	Capacitor	μF	10μF/450V	(3.5UF/450V)×2	(3.5μF/450V)×2
	Speed	r/min	830	800	800
Outdoor coil	Number of rows		2	2	2
	Tube pitch(a)× row pitch(b)	mm	21×13.37	21×13.37	22×19.05
	Fin spacing	mm	1.4	1.4	1.6
	Fin type		Hydrophilic aluminum	Hydrophilic aluminum	Hydrophilic aluminum
	Tube outside dia. and type	mm	φ7, Inner grooved copper tube	φ7 Inner grooved copper tube	φ7.94 Inner grooved copper tube
	Coil length × height × width	mm	890×903×26.74	840×1113×26.74	837×1100×38.1
	Number of circuits		7	4	8
Outdoor air flow		m ³ /h	5000	6800	6850
Outdoor noise level (sound pressure)		dB(A)	57	59	59
Outdoor unit	Dimension(W×H×D)	mm	990×966×354	900×1167×340	900×1167×340
	Packing (W×H×D)	mm	1120×1100×435	1032×1307×443	1032×1307×443
	Net/Gross weight	kg	94/96	102/106	106/111
Refrigerant	Type		R410a	R410a	R410A
	Charged volume	g	2900	3250	3200
Throttle type			capillary	capillary	capillary
Design pressure		MPa	4.2/1.5	4.2/1.5	4.2/1.5
Refrigerant piping	Liquid side/ Gas side	mm	φ12.7/φ19	φ12.7/φ19	φ12.7/φ19
	Max. pipe length	m	30	50	50
	Max. difference in level	m	20	25	25
Ambient temp.		°C	cooling: 21~43; heating:-5~24	cooling: 21~43; heating:-5~24	cooling: 21~43; heating:-5~24

- Notes:**
- Nominal cooling capacities are based on the following conditions:
Indoor temp: 27°CDB, 19°CWB; Outdoor temp: 35°CDB;
 - Nominal heating capacities are based on the following conditions:
Indoor temp: 20°CDB; Outdoor temp: 7°CDB, 6°CWB;
 - Actual noise level may differ, depending on the room structure, etc, since these noise values are from an anechoic room.

2. Dimensions

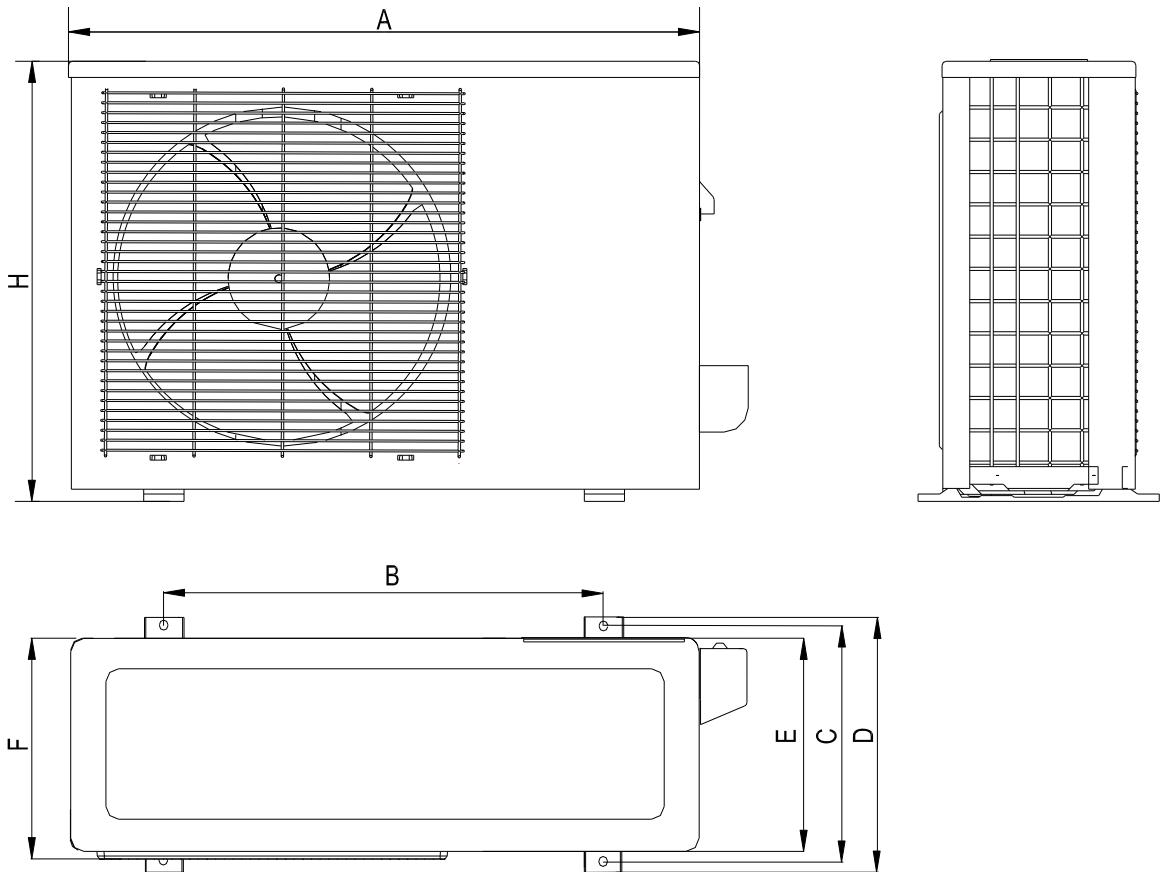

mm

Model	A	B	C	D	E	F	H
SOB-50VA	762	530	290	315	270	282	593
SOB-60VA	842	560	335	360	312	324	695
SOB-100YA	990	624	366	396	340	354	966

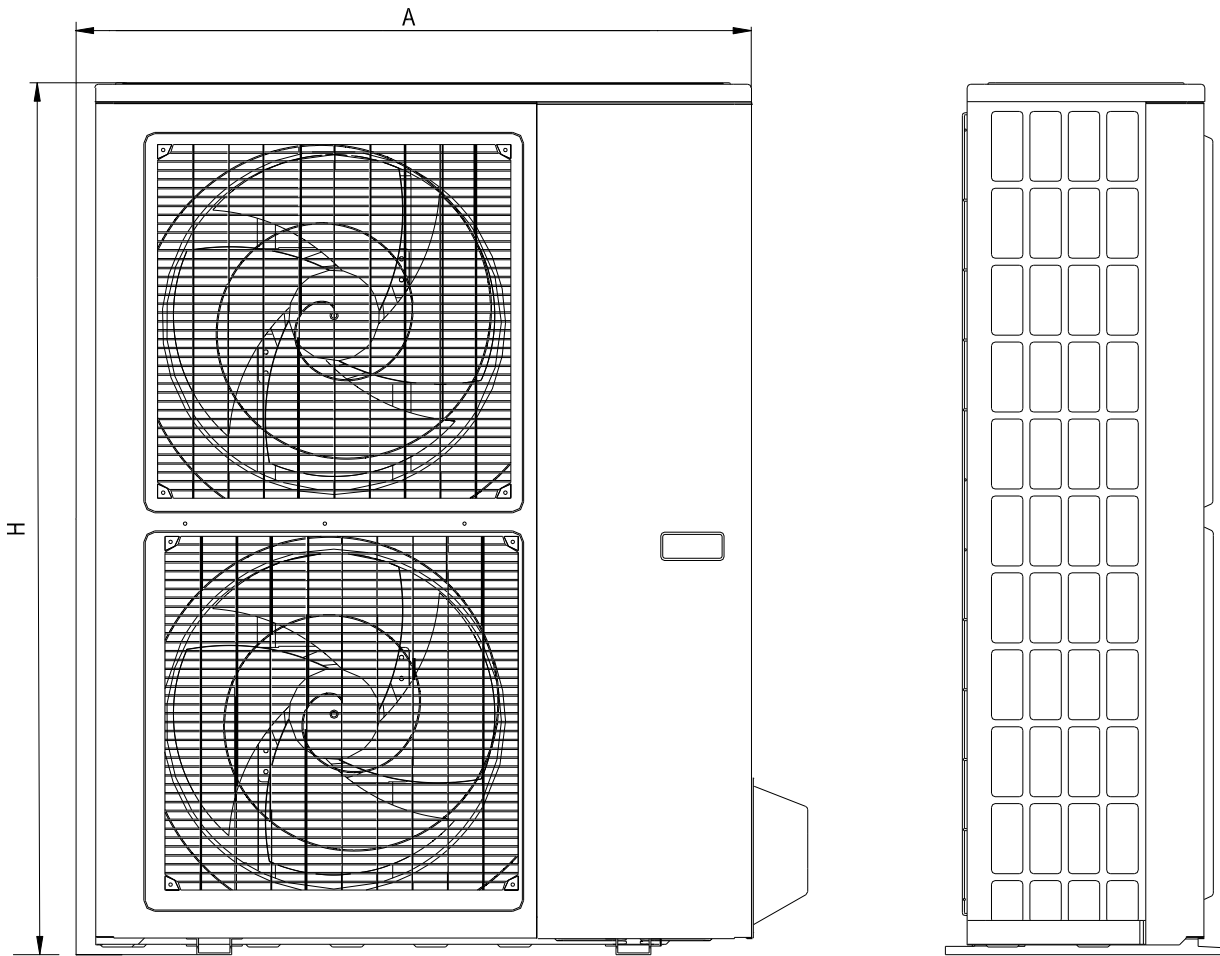

Model	A	B	C	D	E	F	H
SOB-140YA	900	590	378	400	330	340	1167
SOB-200YA	900	590	378	400	330	340	1167

mm

3. Service Space

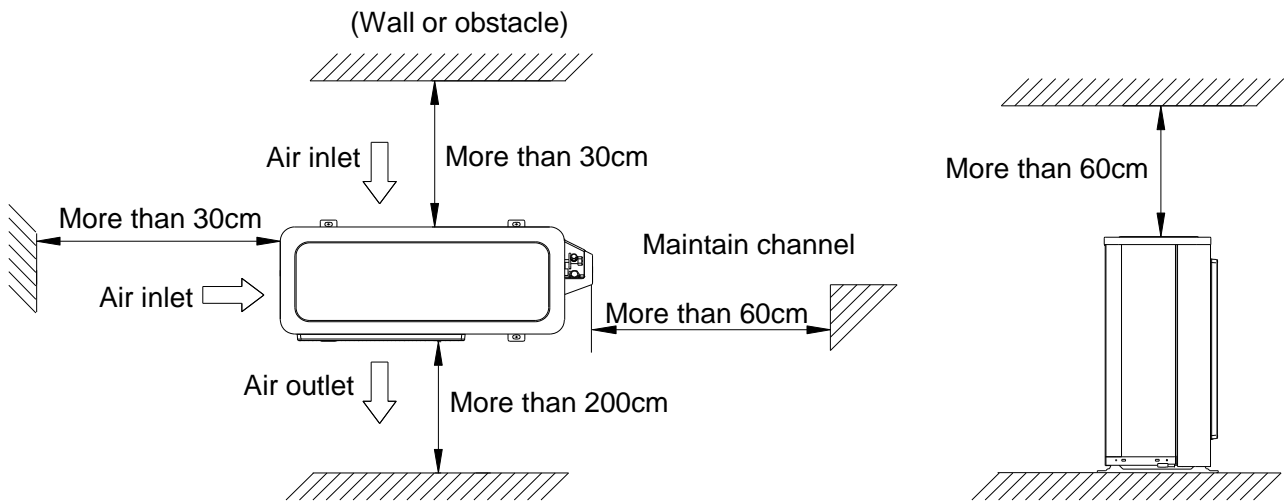

4. Piping Diagrams

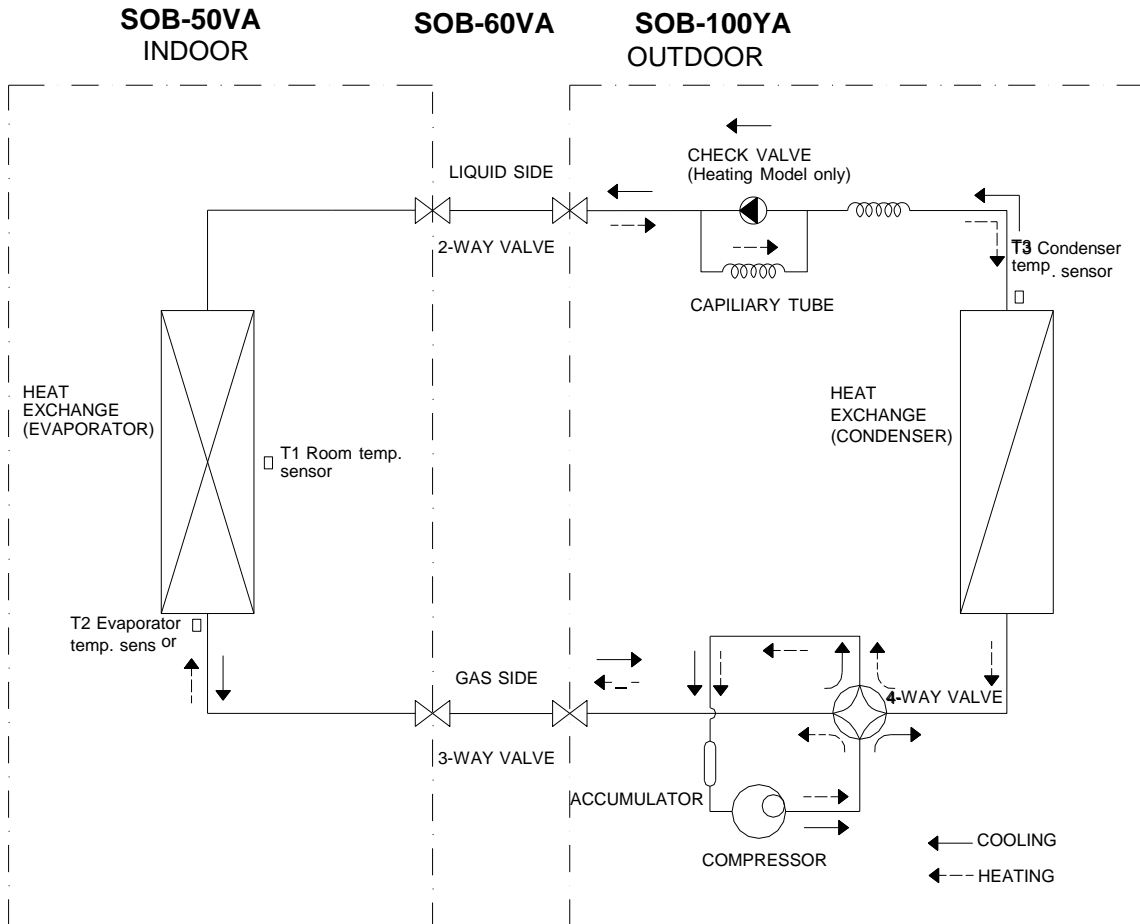

For **SOB-50VA**, **SOB-60VA**, the accumulator is not included.

SOB-140YA

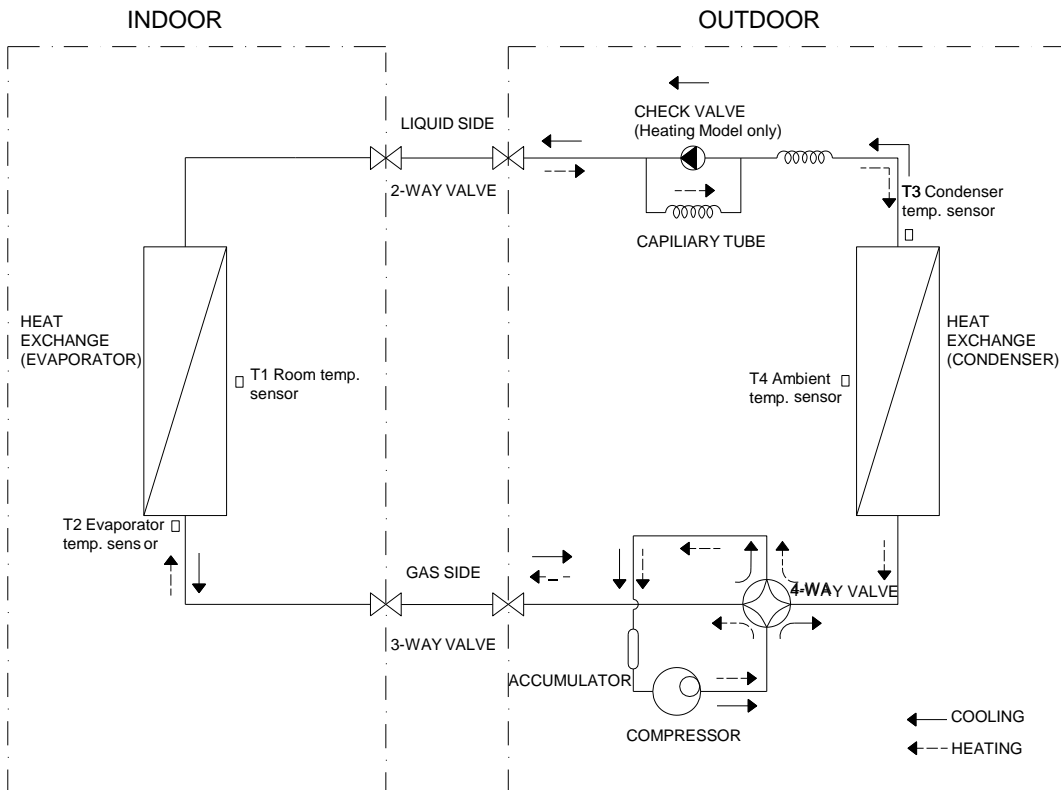

SOB-200YA

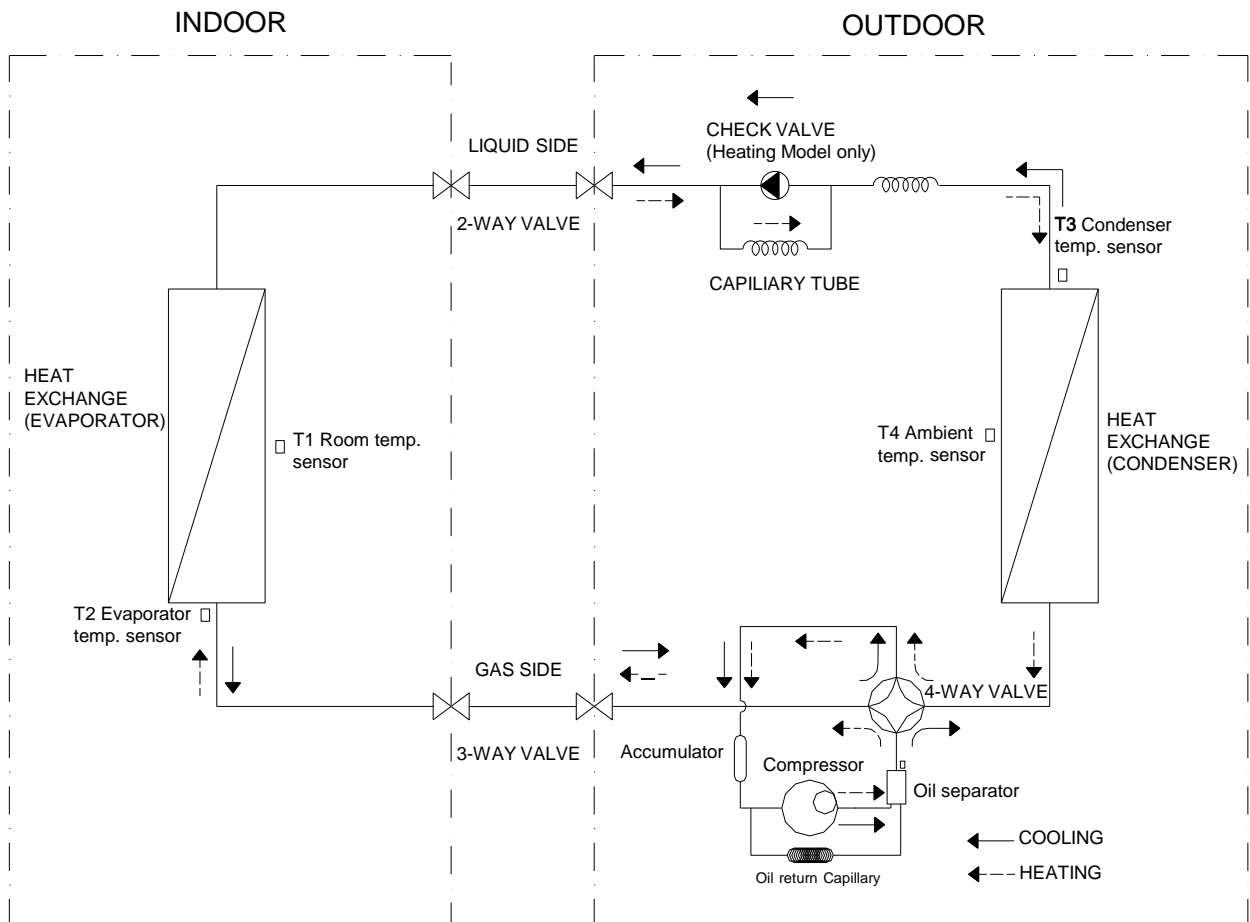

5. Wiring Diagrams

SOB-50VA

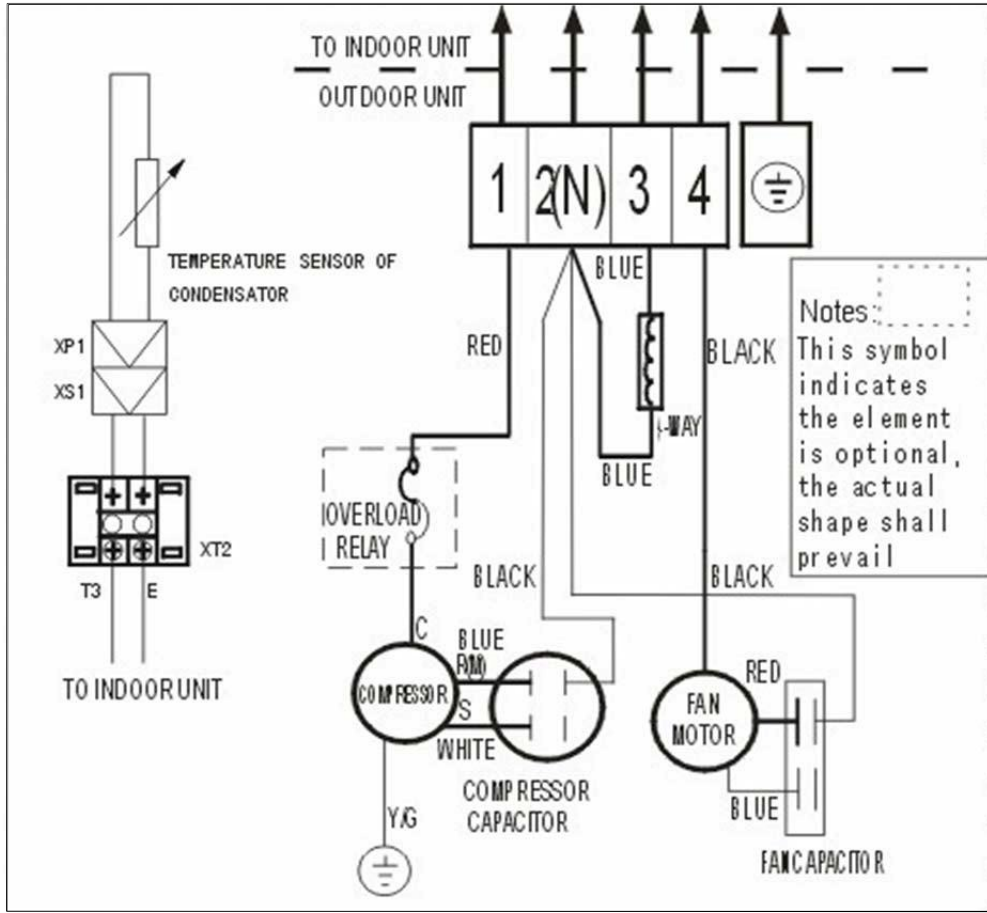

SOB-60VA

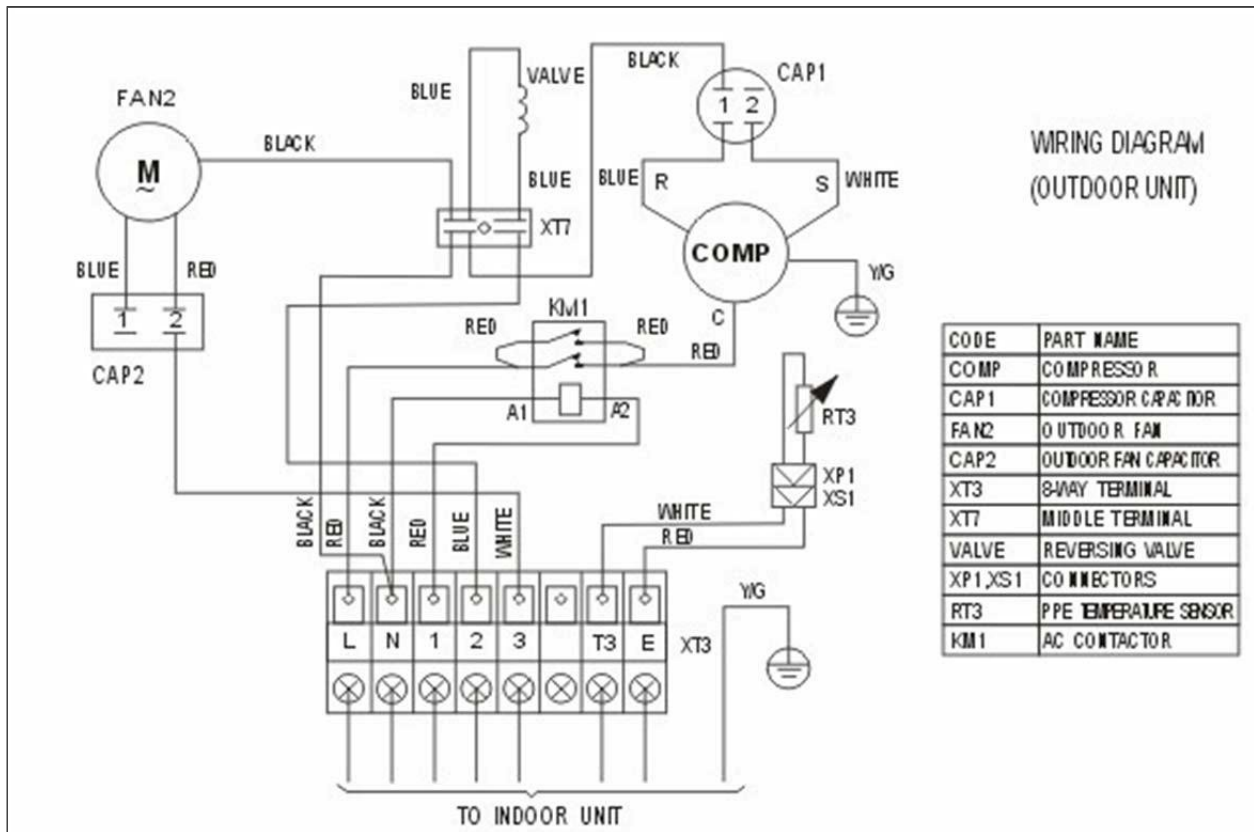

SOB-100YA

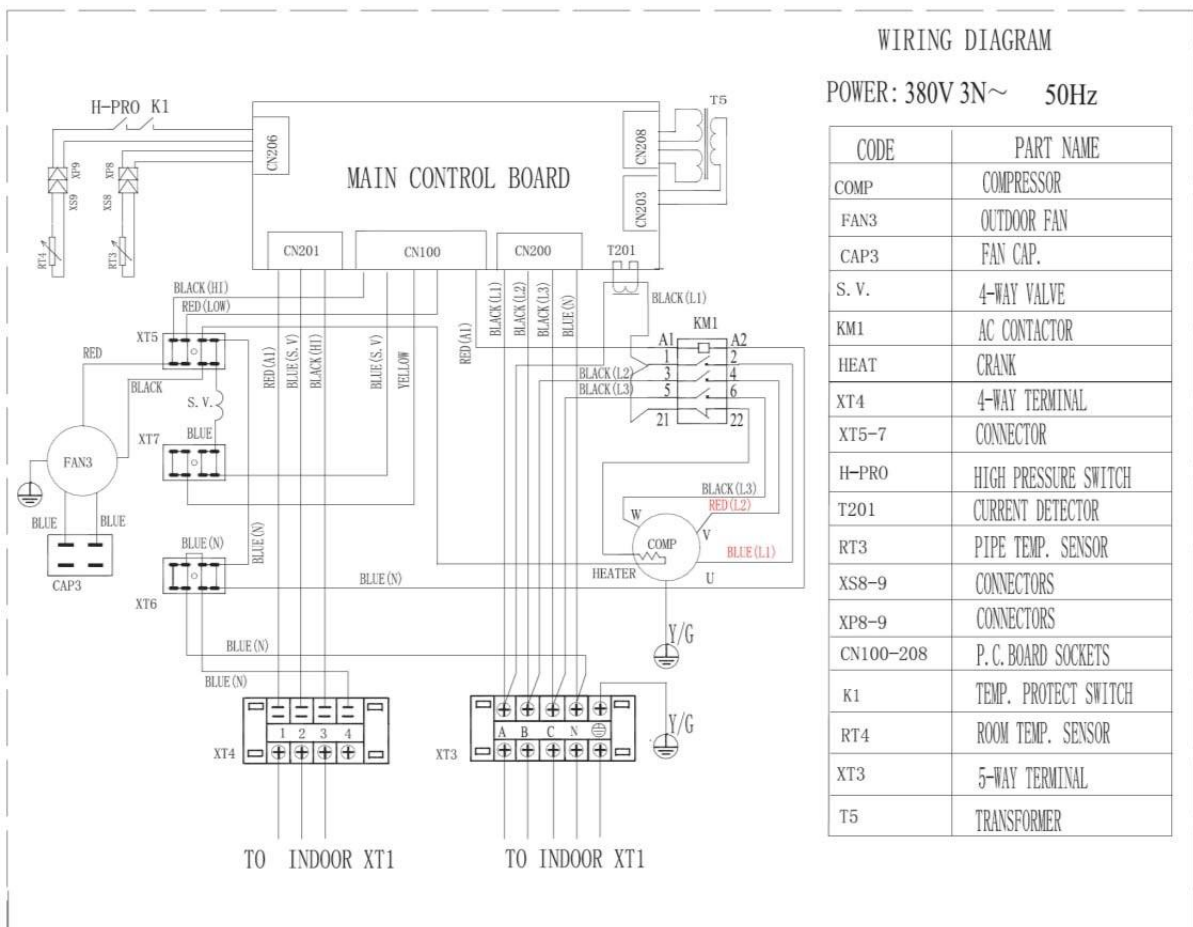

SOB-140YA SOB-200YA

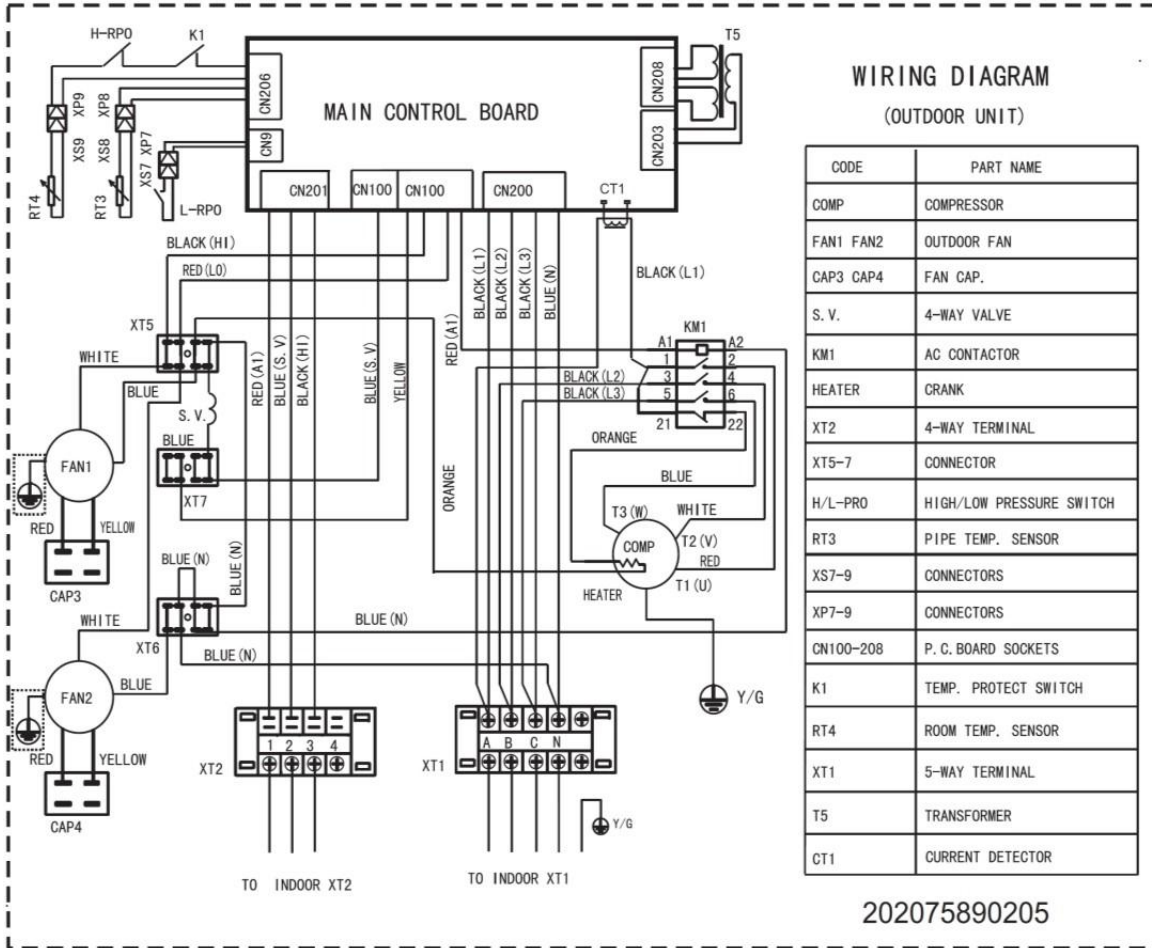

6. Electric Characteristics

Model	Outdoor Unit			
	Hz	Voltage	Min.	Max.
SOB-50VA	50	220~240V	198V	254V
SOB-60VA	50	220~240V	198V	254V
SOB-100YA	50	380~415V	342V	418V
SOB-140YA	50	380~415V	342V	418V
SOB-200YA	50	380~415V	342V	418V

7. Operation Limits

Operation mode	Outdoor temperature(°C)	Room temperature(°C)
Cooling operation	21~43	17~30
Heating operation	-5~24	17~30

Cooling

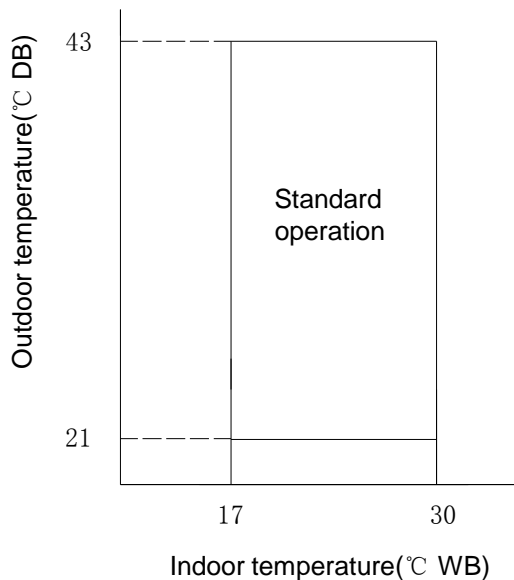

Heating

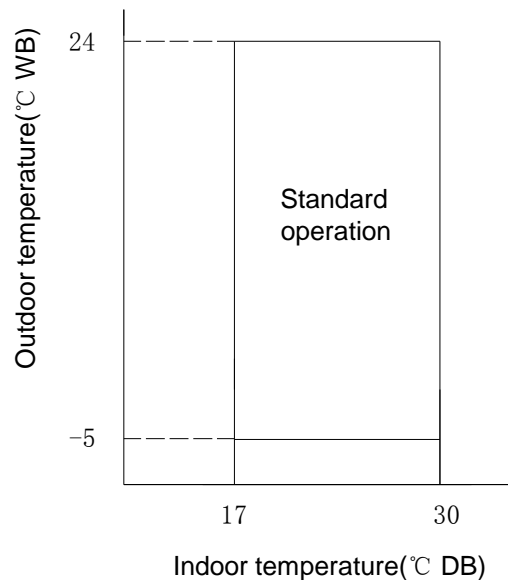

8. Sound Levels

18000Btu/h-48000Btu/h

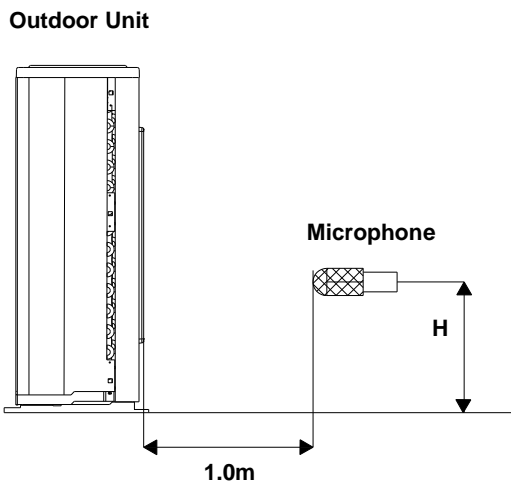

Note: H= 0.5 × height of outdoor unit

60000Btu/h

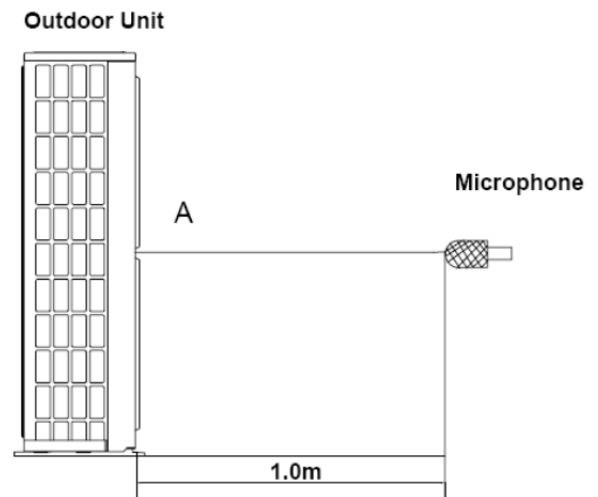

Note: The point A is in the middle of the whole outdoor panel.

Model	Noise level dB(A)
SOB-50VA	54
SOB-60VA	55
SOB-100YA	57
SOB-140YA	59
SOB-200YA	59

9. Troubleshooting

9.1. Self-diagnosis

Indoor unit's LED indication

(1) For Big Four-way cassette

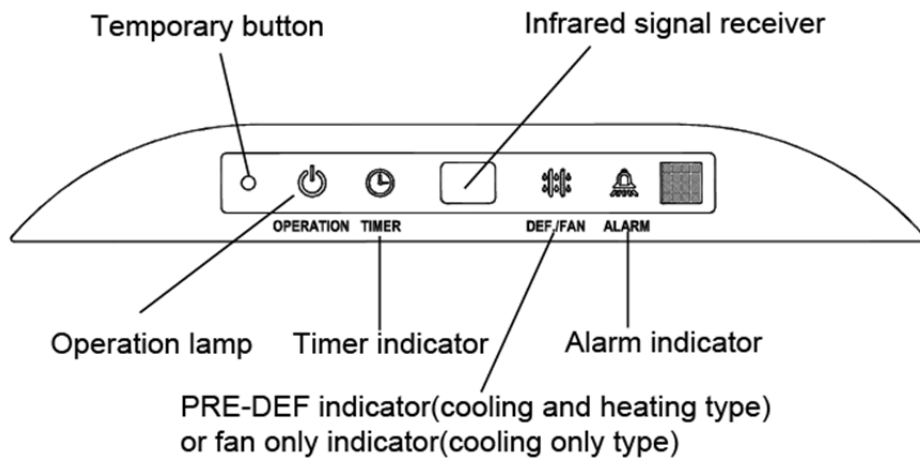

NO.	MALFUNCTION & PROTECTION DEFINE	LED 1 OPERATION	LED2 TIMER	LED3 DEF.FAN	LED4 ALARM	DISPLAY DIGITAL TUBE
1	Room temperature sensor checking channel is abnormal	●	○	●	●	E2
2	Pipe temperature sensor checking channel is abnormal	○	●	●	●	E3
3	Outdoor TEMP. sensor checking channel is abnormal	●	●	○	●	E4
4	Outdoor malfunction	○	○	○	○	E6
5	EEPROM malfunction	○	○	●	●	E7
6	Water-level alarm malfunction	●	●	●	○	E8

● Extinguish ○ Flashing at 5HZ ○ Flashing at 1HZ

(2) For A5 Duct

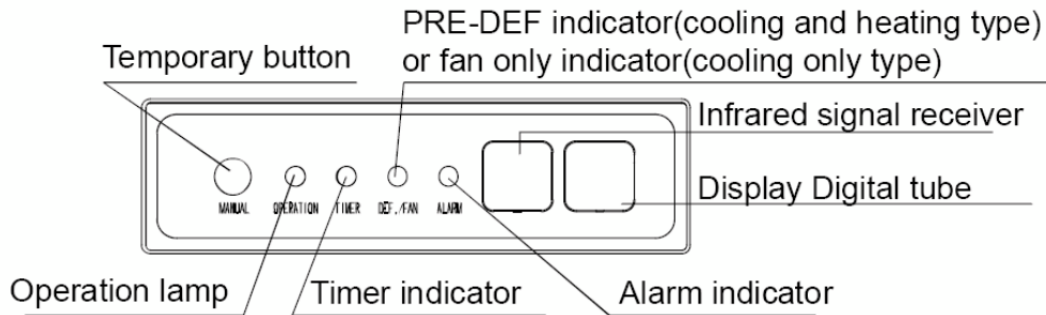

NO.	MALFUNCTION & PROTECTION DEFINE	LED1 OPERATION	LED2 TIMER	LED3 DEF.FAN	LED4 ALARM	DISPLAY DIGITAL TUBE
1	Room temperature sensor checking channel is abnormal	●	◎	●	●	E2
2	Pipe temperature sensor checking channel is abnormal	◎	●	●	●	E3
3	Outdoor TEMP. sensor checking channel is abnormal	●	●	◎	●	E4
4	Outdoor malfunction	◎	◎	◎	◎	E6
5	EEPROM malfunction	◎	◎	●	●	E7
6	Water-level alarm malfunction	●	●	●	◎	E8

● Extinguish ◎ Flashing at 5HZ ○ Flashing at 1HZ

(3) For AHU indoor unit

The LED on indoor PCB

Type	Contents	LED1	LED2	LED3
ERROR	Pipe Temp sensor error	Quick flash	Off	Off
ERROR	Wire controller input error	Quick flash	Off	Quick flash

(4) For CONSOLE

NO.	running lamp	timer lamp	defrosting lamp	Malfunction for unuit of 12000Btu/h	Malfunction for unuit of 18000Btu/h
1	☆	×	×	Room temperature sensor checking channel is abnormal	Room temperature sensor checking channel is abnormal
2	×	×	☆	Evaporator sensor checking channel is abnormal	Mode impact
3	☆	☆	☆	Condenser sensor checking channel is abnormal	—————
4	×	☆	×	Room Circuit malfunction	Room Circuit malfunction
5	×	×	◎	—————	Outdoor unit malfunction

(× Extinguish, ☆ Flash at 5Hz, ◎ Flash at 0.5Hz)

(5)For the other types indoor unit

No.	Type	Contents	LED Flashing	Remark
1	Normal	Standing-by	Operation lamp flashes at 0.5Hz	Nothing wrong with the unit when LED indicate these contents.
2	Normal	System Off	All lamps are off	
3	Normal	System startup	Operation lamp on	
4	Normal	Forced cooling	Operation lamp flashes at 5Hz, Timer lamp on	
5	Protection	Over current protection of the compressor occurs 4 times in 1h	Lamps of operation, timer, defrosting (only fan) flashing simultaneously at 5Hz.	Whole unit is shut down. It cannot recover unless power is cut off
6	Protection	Outdoor protection (lack of phase, phase sequence and temperature protection)	All lamps flashing at 5Hz	Recover automatically after errors are eliminated (For T3 malfunction of 5HP, can't recover automatically)
7	Error	Room temperature sensor checking channel is abnormal	Timer lamp flashing at 5Hz	
8	Error	Evaporator sensor checking channel is abnormal	Operation lamp flashing at 5Hz	
9	Error	Condenser sensor checking channel is abnormal	Defrosting lamp flashing at 5Hz	
10	Error	Communication of EEPROM malfunction	Operation lamp and timer lamp flashing at 5Hz	
11	Error	Water level alarm/pump sensor malfunction	Alarm lamp flashes at 5Hz	

LEDs' for the indication of outdoor trouble

Type	Contents	LED1	LED2	LED3
Trouble	Phase sequence	Flash	Off	Off
Trouble	Lack of phase(A,B)	Flash	Off	Off
Trouble	Lack of phase(C)	Off	Off	Off
Trouble	Protection of Low pressure	Flash	Flash	Off
Trouble	Overload of current	Off	Off	Flash
Trouble	Communication malfunction	Flash	Off	Flash
Trouble	Open-circuit and short-circuit trouble of T3	Off	Flash	Flash
Trouble	Open-circuit and short-circuit trouble of T4	Off	Flash	Off
Trouble	High temperature protection of condenser	Flash	Flash	Flash

Note:

1. If the LED1-LED3 are flashing slowly, means the system is stand-by.
2. T3: Outdoor condenser temperature sensor
3. T4: Outdoor ambient temperature sensor

9.2. Solving steps for typical malfunction

(1) For indoor unit

a. Indoor room temperature sensor is abnormal

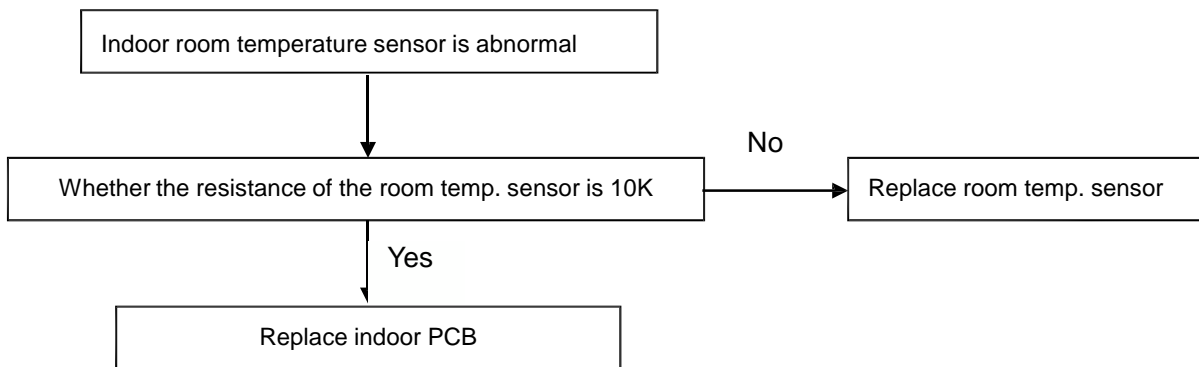

b. Evaporator temperature sensor is abnormal

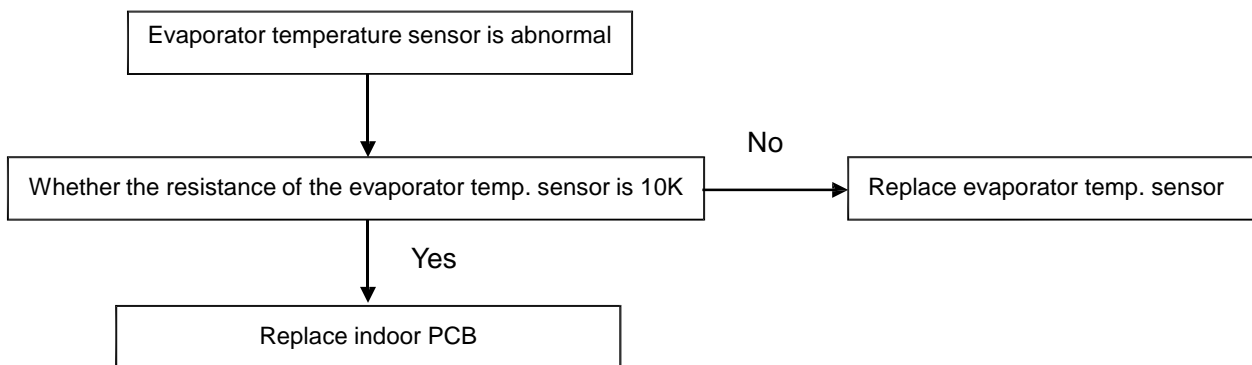

c. Condenser temperature sensor is abnormal

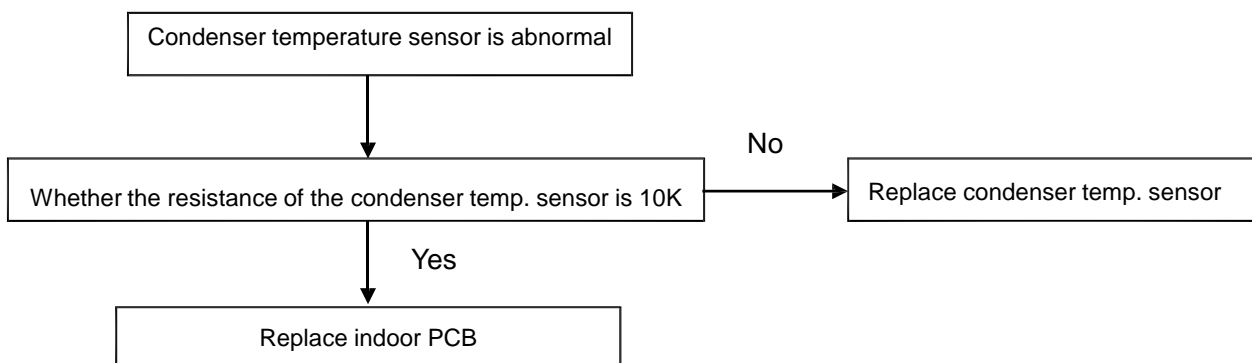

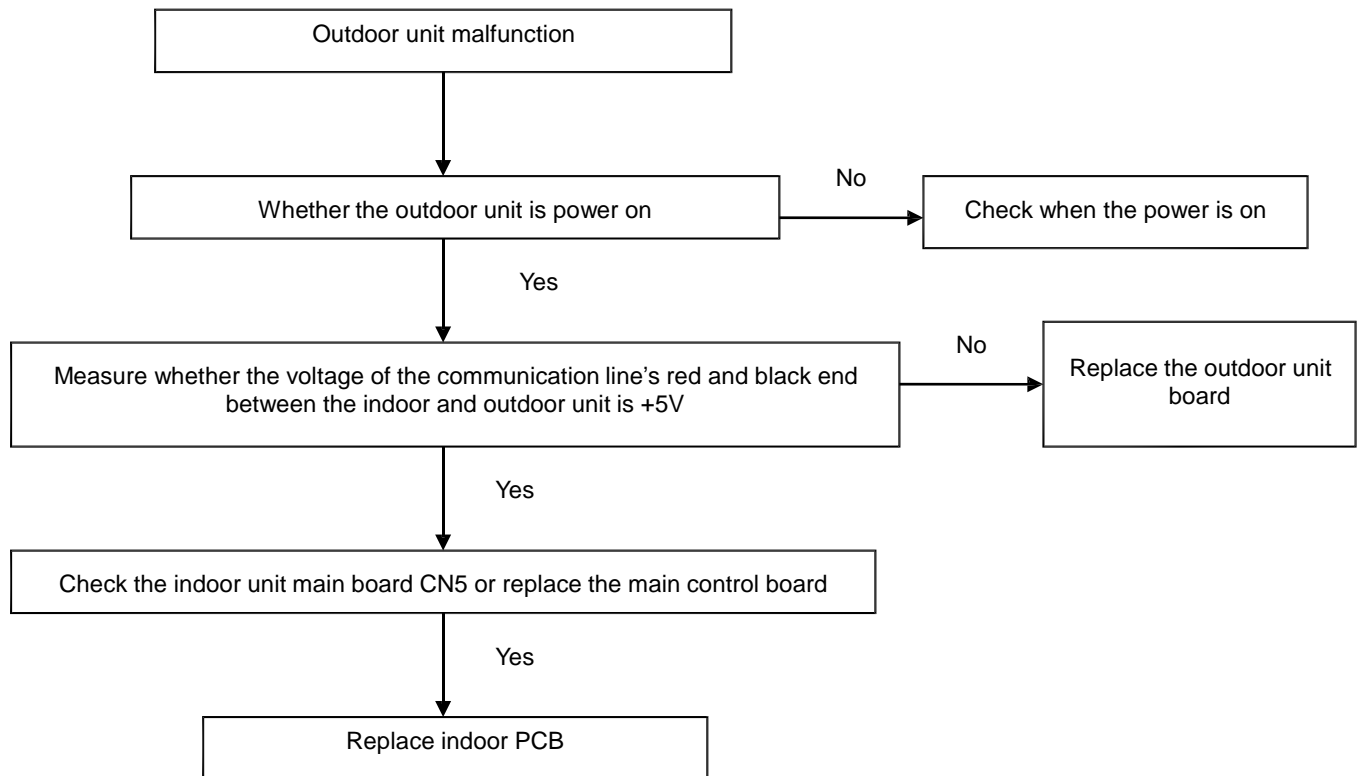
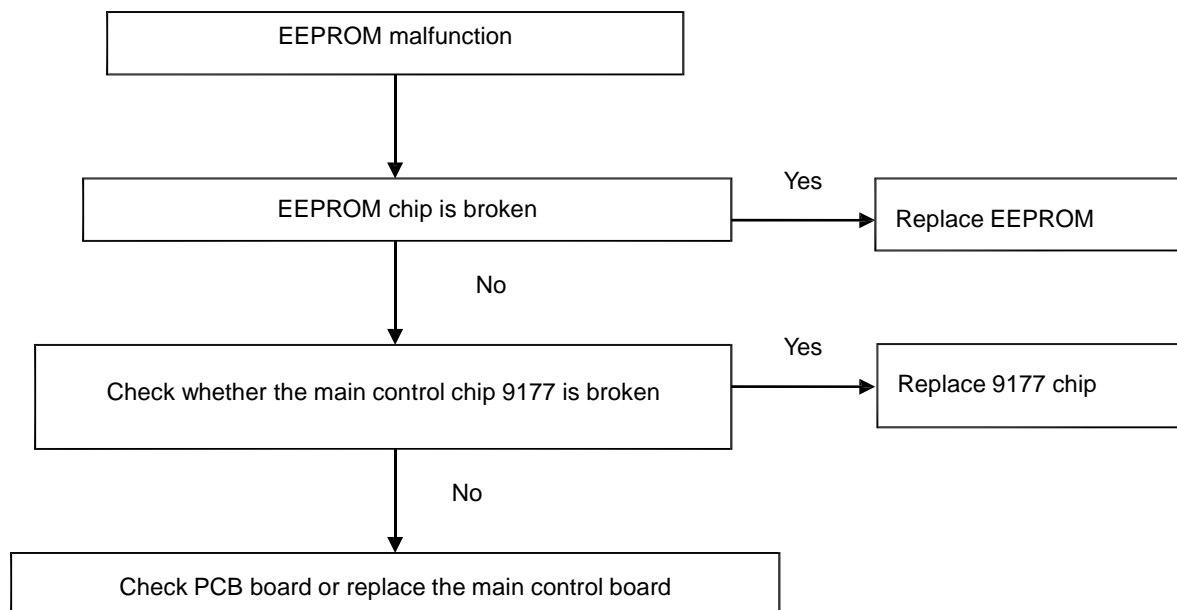
d. Outdoor unit malfunction**e. EEPROM malfunction**

f. Full-water malfunction

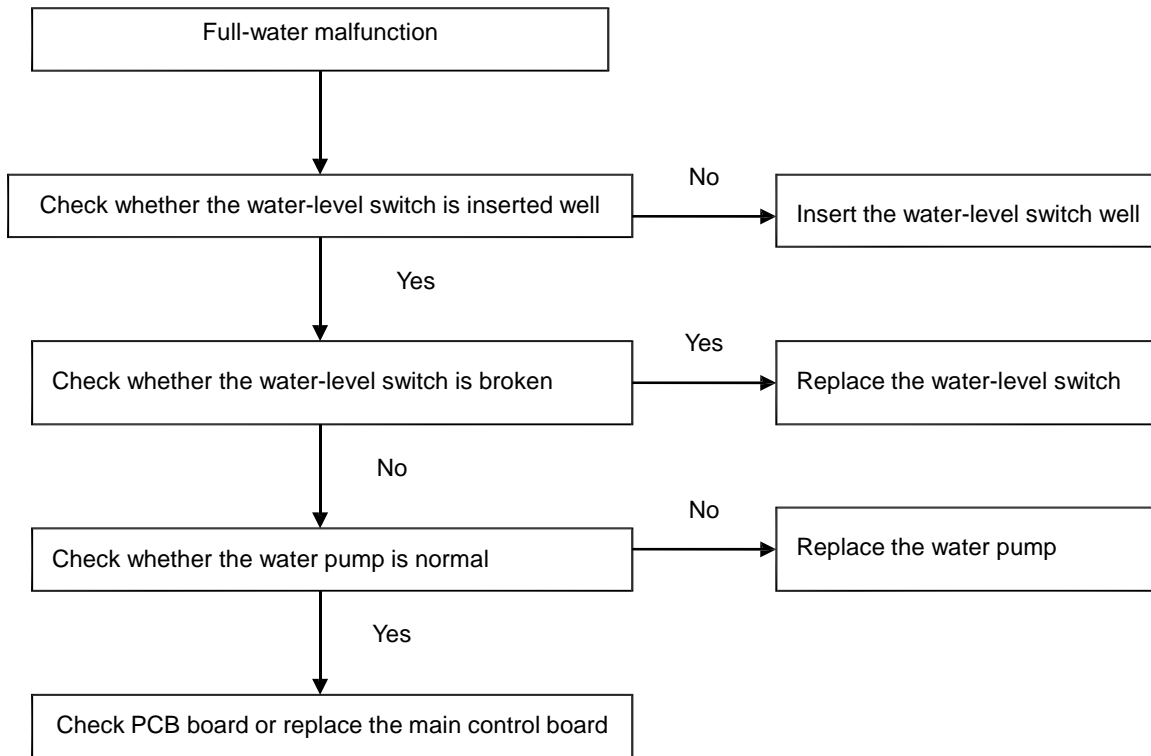

g. Temperature sensor error of water pump

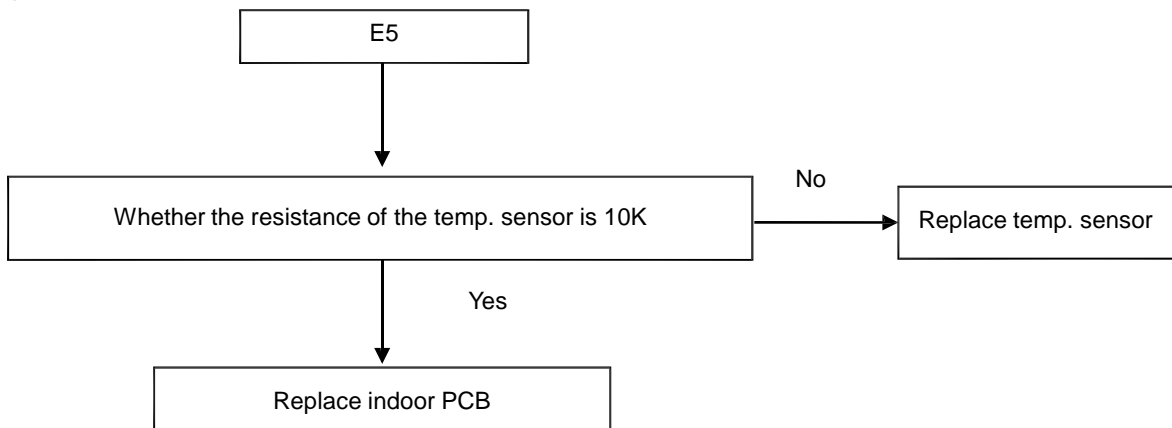

(2) For the outdoor unit

a. Phase sequence error:

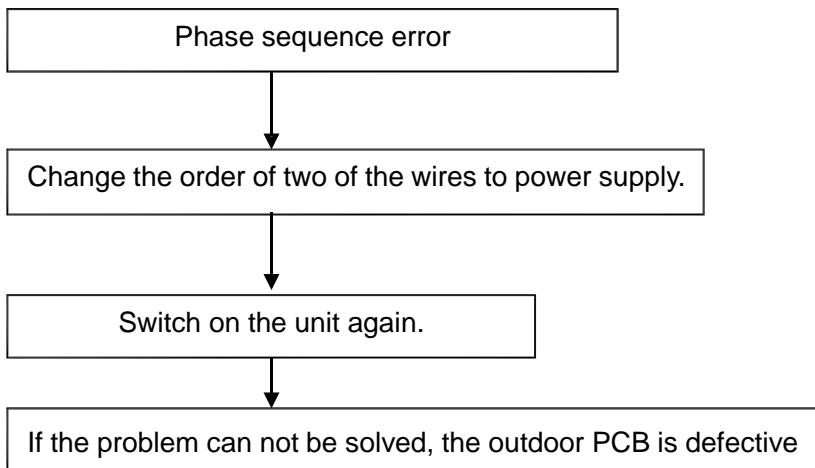

b. Overload of current

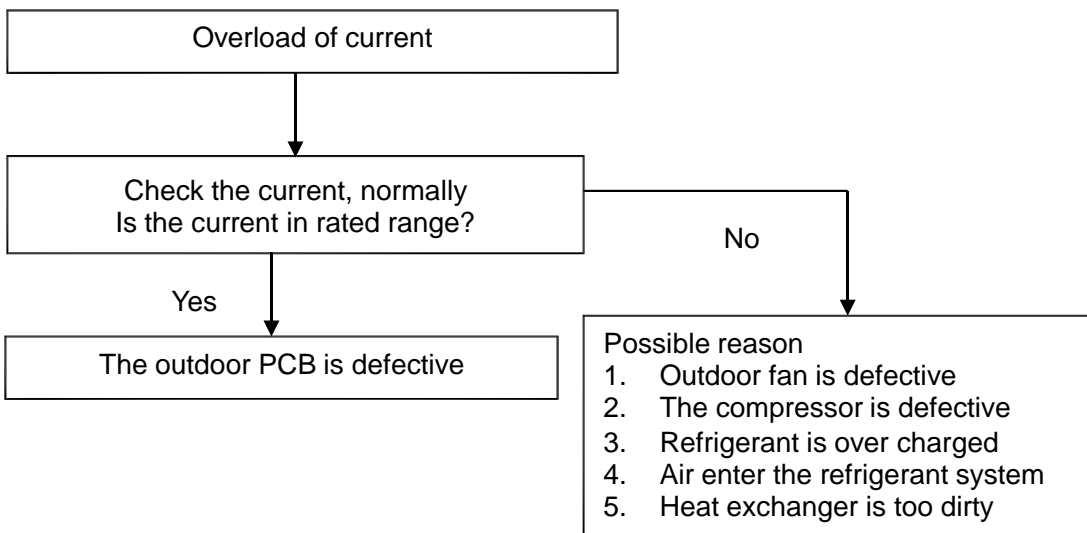

c. Lack of phase

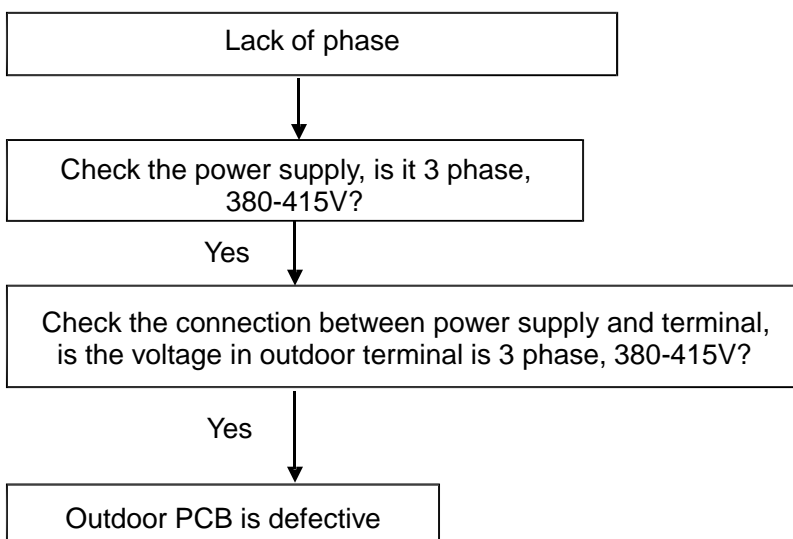

d. Protection of pressure or temp.

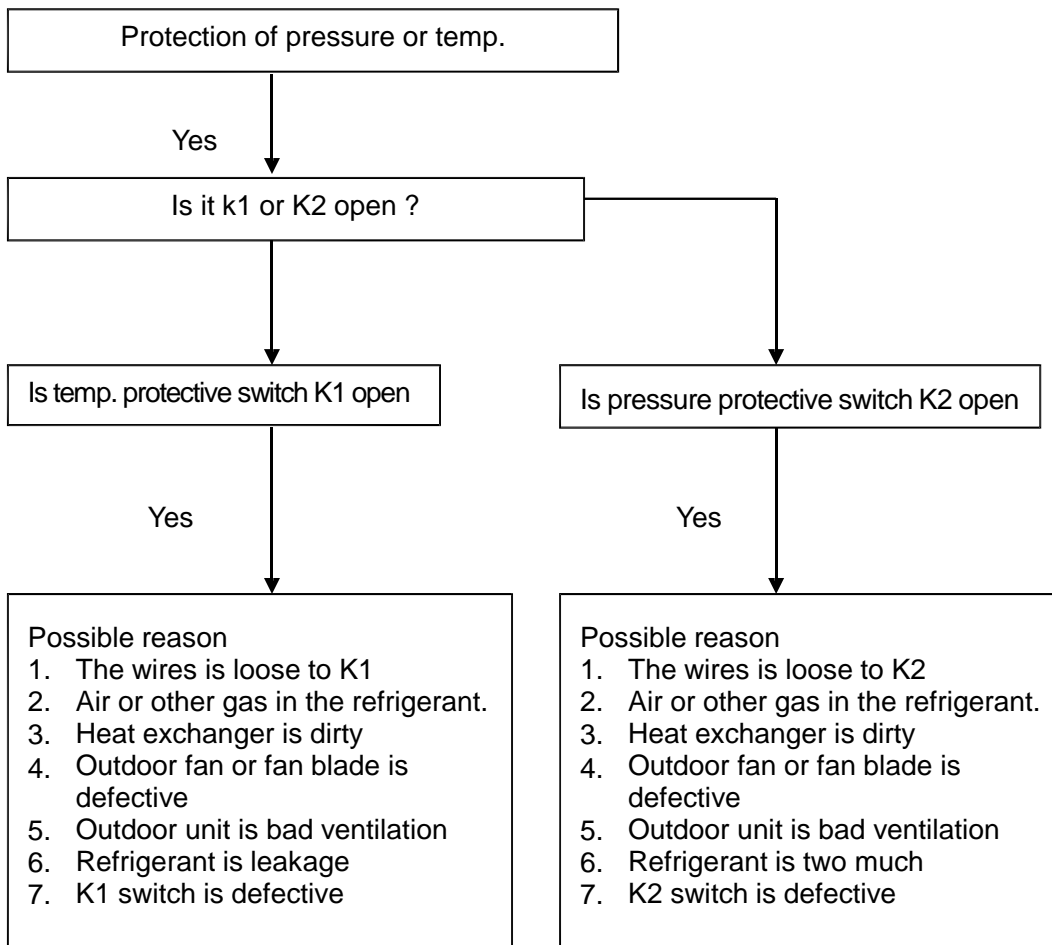

e. Open-circuit and short-circuit trouble of T3

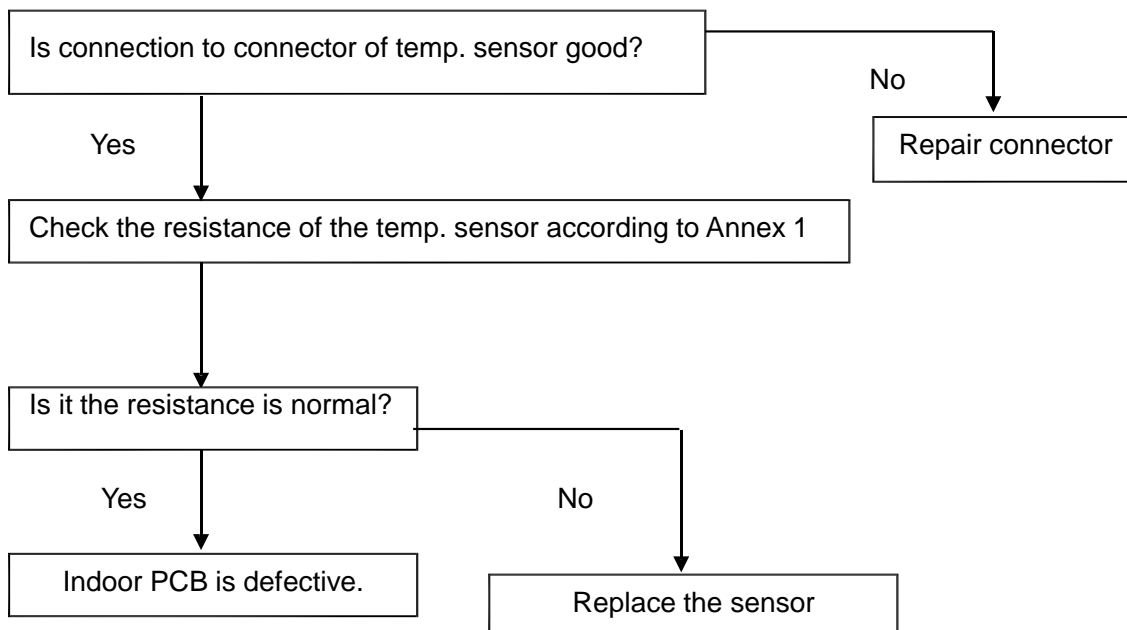

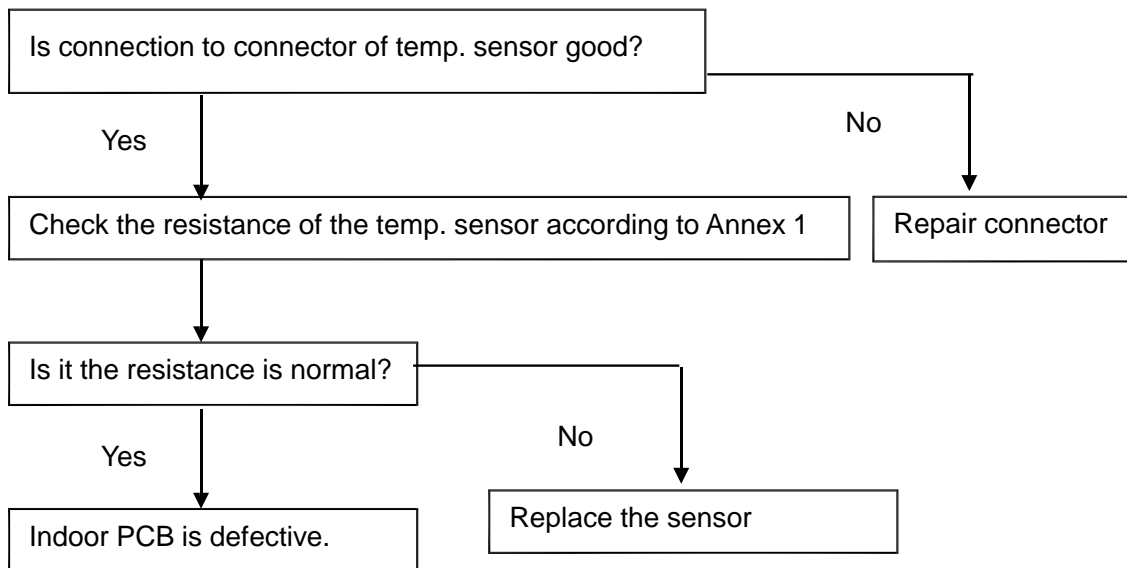
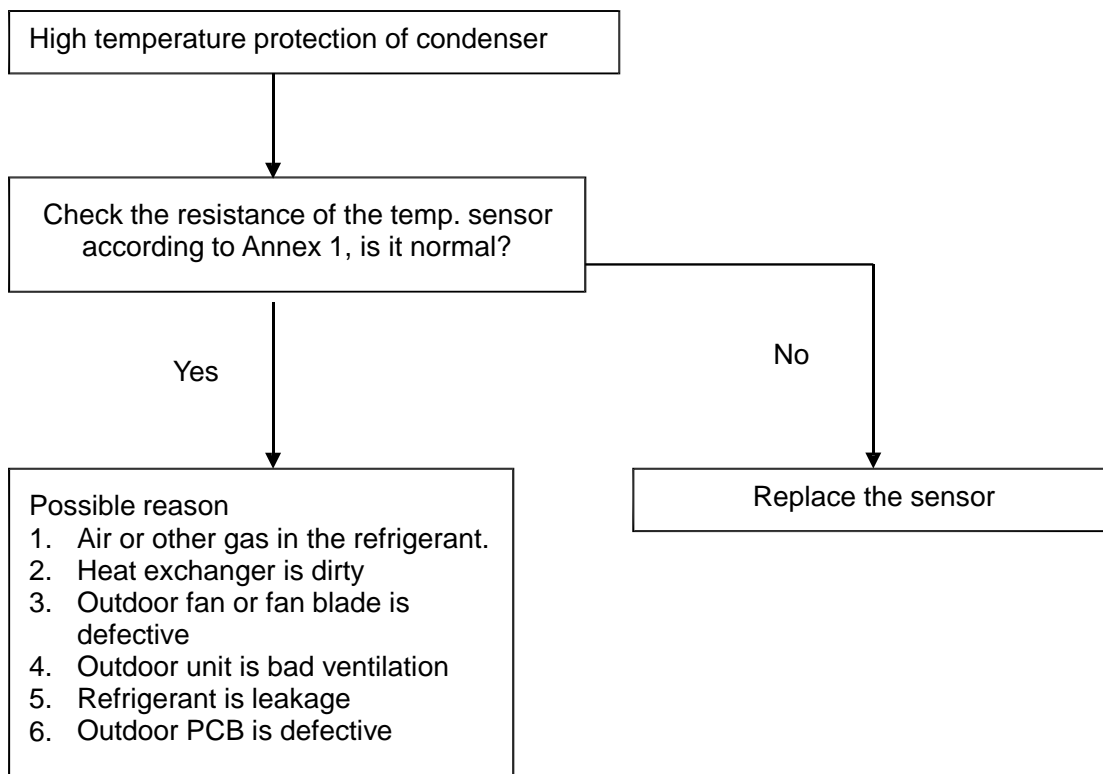
f. Open-circuit and short-circuit trouble of T4**g. High temperature protection of condenser**

Appendix Indoor Temp. and Pipe Temp. Sensor Resistance Value Table (°C--K)

°C	K Ohm	°C	K Ohm	°C	K Ohm	°C	K Ohm
-20	115.266	20	12.6431	60	2.35774	100	0.62973
-19	108.146	21	12.0561	61	2.27249	101	0.61148
-18	101.517	22	11.5000	62	2.19073	102	0.59386
-17	96.3423	23	10.9731	63	2.11241	103	0.57683
-16	89.5865	24	10.4736	64	2.03732	104	0.56038
-15	84.2190	25	10.0000	65	1.96532	105	0.54448
-14	79.3110	26	9.55074	66	1.89627	106	0.52912
-13	74.5360	27	9.12445	67	1.83003	107	0.51426
-12	70.1698	28	8.71983	68	1.76647	108	0.49989
-11	66.0898	29	8.33566	69	1.70547	109	0.48600
-10	62.2756	30	7.97078	70	1.64691	110	0.47256
-9	58.7079	31	7.62411	71	1.59068	111	0.45957
-8	56.3694	32	7.29464	72	1.53668	112	0.44699
-7	52.2438	33	6.98142	73	1.48481	113	0.43482
-6	49.3161	34	6.68355	74	1.43498	114	0.42304
-5	46.5725	35	6.40021	75	1.38703	115	0.41164
-4	44.0000	36	6.13059	76	1.34105	116	0.40060
-3	41.5878	37	5.87359	77	1.29078	117	0.38991
-2	39.8239	38	5.62961	78	1.25423	118	0.37956
-1	37.1988	39	5.39689	79	1.21330	119	0.36954
0	35.2024	40	5.17519	80	1.17393	120	0.35982
1	33.3269	41	4.96392	81	1.13604	121	0.35042
2	31.5635	42	4.76253	82	1.09958	122	0.3413
3	29.9058	43	4.57050	83	1.06448	123	0.33246
4	28.3459	44	4.38736	84	1.03069	124	0.32390
5	26.8778	45	4.21263	85	0.99815	125	0.31559
6	25.4954	46	4.04589	86	0.96681	126	0.30754
7	24.1932	47	3.88673	87	0.93662	127	0.29974
8	22.5662	48	3.73476	88	0.90753	128	0.29216
9	21.8094	49	3.58962	89	0.87950	129	0.28482
10	20.7184	50	3.45097	90	0.85248	130	0.27770
11	19.6891	51	3.31847	91	0.82643	131	0.27078
12	18.7177	52	3.19183	92	0.80132	132	0.26408
13	17.8005	53	3.07075	93	0.77709	133	0.25757
14	16.9341	54	2.95896	94	0.75373	134	0.25125
15	16.1156	55	2.84421	95	0.73119	135	0.24512
16	15.3418	56	2.73823	96	0.70944	136	0.23916
17	14.6181	57	2.63682	97	0.68844	137	0.23338
18	13.9180	58	2.53973	98	0.66818	138	0.22776
19	13.2631	59	2.44677	99	0.64862	139	0.22231

Part 4

Installation

1. Precaution on Installation	107
2. Vacuum Dry and Leakage Checking	108
3. Additional Refrigerant Charge	110
4. Water Drainage	111
5. Insulation Work	114
6. Wiring	116
7. Test Operation	117

1. Precaution on Installation

- 1). Measure the necessary length of the connecting pipe, and make it by the following way.
 - a. Connect the indoor unit at first, then the outdoor unit.
Bend the tubing in proper way. Do not harm them.

Specially Notice the pipe length/height/dimension of each capacity.

Maximum pipe length

Model	Max. Length	Max. Elevation
18,000Btu/h~24,000Btu/h	25m	15m
36,000Btu/h	30m	20m
48,000Btu/h~60,000Btu/h	50m	25m

Piping sizes

Model	Liquid(mm)	Gas(mm)
18,000Btu/h	6.4	12.7
24,000Btu/h	9.5	15.9
36,000Btu/h~60,000Btu/h	12.7	19

CAUTIONS

- Daub the surfaces of the flare pipe and the joint nuts with frozen oil, and wrench it for 3~4 rounds
- With hands before fasten the flare nuts.
- Be sure to use two wrenches simultaneously when you connect or disconnect the pipes.

Pipe gauge	Tightening torque	Flare dimension A		Flare shape
		Min (mm)	Max	
Φ6.4	15~16N.m (153~163 kgf.cm)	8.3	8.7	
Φ9.5	25~26N.m (255~265kgf.cm)	12.0	12.4	
Φ12.7	35~36N.m (357~367kgf.cm)	15.4	15.8	
Φ15.9	45~47N.m (459~480 kgf.cm)	18.6	19.1	
Φ19.1	65~67N.m (663~684kgf.cm)	22.9	23.3	

- b. The stop valve of the outdoor unit should be closed absolutely (as original state). Every time you connect it, first loosen the nuts at the part of stop valve, then connect the flare pipe immediately (in 5 minutes). If the nuts have been loosened for a long time, dusts and other impurities may enter the pipe system and may cause malfunction later. So please expel the air out of the pipe with refrigerant before connection.
 - c. Expel the air after connecting the refrigerant pipe with the indoor unit and the outdoor unit. Then fasten the nuts at the repair-points.
- 2) Locate The Pipe
 - a. Drill a hole in the wall (suitable just for the size of the wall conduit), then set on the fittings such as the wall conduit and its cover.
 - b. Bind the connecting pipe and the cables together tightly with binding tapes. Do not let air in, which will cause water leakage by condensation.
 - c. Pass the bound connecting pipe through the wall conduit from outside. Be careful of the pipe allocation to do no damage to the tubing.
 - 3) Connect the pipes.
 - 4) Then, open the stem of stop valves of the outdoor unit to make the refrigerant pipe connecting the indoor unit with the outdoor unit in fluent flow.
 - 5) Be sure of no leakage by checking it with leak detector or soap water.
 - 6) Cover the joint of the connecting pipe to the indoor unit with the soundproof / insulating sheath (fittings), and bind it well with the tapes to prevent leakage.

2. Vacuum Dry and Leakage Checking

2.1 Vacuum Dry: use vacuum pump to change the moisture (liquid) into steam (gas) in the pipe and discharge it out of the pipe to make the pipe dry. Under one atmospheric pressure, the boiling point of water(steam temperature) is 100°. Use vacuum pump to make the pressure in the pipe near vacuum state, the boiling point of water falls relatively. When it falls under outdoor temperature, the moisture in the pipe will be vaporized.

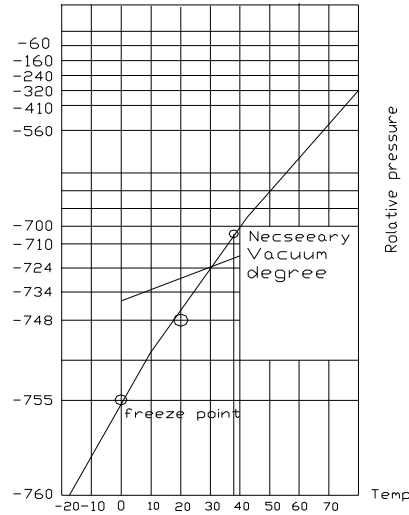

2.2 Vacuum dry procedure

There are two methods of vacuum dry due to different construction environment: common vacuum dry, special vacuum dry.

①. Common vacuum dry procedure

- Vacuum dry (for the first time)---connect the all-purpose detector to the inlet of liquid pipe and gas pipe, and run the vacuum pump more than two hours (the vacuum pump should be below -755mmHg)
- If the pump can't achieve below -755mmHg after pumping 2 hours, moisture or leakage point will still exist in the pipe. At this time, it should be pumped 1 hour more.
- If the pump can't achieve -755mmHg after pumping 3 hours, please check if there are some leakage points.
- Vacuum placement test: place 1 hour when it achieves -755mmHg, pass if the vacuum watch shows no rising. If it rises, it shows there's moisture or leakage point.
- Vacuuming from liquid pipe and gas pipe at the same time.
- Sketch map of common vacuum dry procedure.

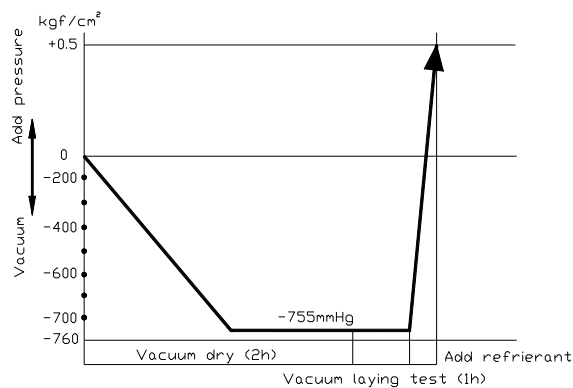

②. Special vacuum dry procedure

- This vacuum dry method is used in the following conditions:
- There's moisture when flushing the refrigerant pipe.
- Rainwater may enter into the pipe.
- Vacuum dry for the first time 2h pumping

③. Vacuum destroy for the second time Fill nitrogen to 0.5Kgf/cm²

Because nitrogen is for drying gas, it has vacuum drying effect during vacuum destroy. But if the moisture is too much, this method can't dry thoroughly. So, please pay more attention to prevent water entering and forming condensation water.

④. Vacuum dry for the second time 1h pumping

Determinant: Pass if achieving below -755mmHg. If -755mmHg can't be achieved in 2h, repeat procedure

③ and ④.

⑤. Vacuum placing test 1h

⑥. Sketch map of special vacuum dry procedure

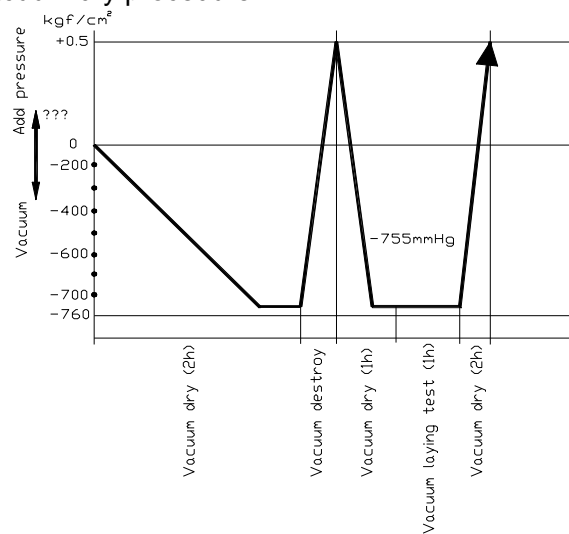

3. Additional Refrigerant Charge

Caution

- Refrigerant cannot be charged until field wiring has been completed.
- Refrigerant may only be charged after performing the leak test and the vacuum pumping.
- When charging a system, care shall be taken that its maximum permissible charge is never exceeded, in view of the danger of liquid hammer.
- Charging with an unsuitable substance may cause explosions and accidents, so always ensure that the appropriate refrigerant is charged.
- Refrigerant containers shall be opened slowly.
- Always use protective gloves and protect your eyes when charging refrigerant.

The outdoor unit is factory charged with refrigerant. Calculate the added refrigerant according to the diameter and the length of the liquid side pipe of the outdoor unit/indoor unit

R(g) \ L(m) \ D(mm)	φ6.4	φ9.5	φ12.7
Less than 5m (One-way)	—	—	—
Added Refrigerant When Over 5m(One-way)	11g/m×(L-5)	30g/m×(L-5)	60g/m×(L-5)

Remark:

R (g): Additional refrigerant to be charged

L (m): The length of the refrigerant pipe (one-way)

D (mm): Liquid side piping diameter

4. Water Drainage

4.1 Gradient and Supporting

4.1.1 Keep the drainpipe sloping downwards at a gradient of at least 1/100. Keep the drainpipe as short as possible and eliminate the air bubble.

4.1.2 The horizontal drainpipe should be short. When the pipe is too long, a prop stand must be installed to keep the gradient of 1/100 and prevent bending. Refer to the following table for the specification of the prop stand.

	Diameter	Distance between the prop stands
Hard PVC pipe	25~40mm	1.5~2m

4.1.3. Precautions

- ① The diameter of drainpipe should meet the drainage requirement at least.
- ② The drainpipe should be heat-insulated to prevent atomization.
- ③ Drainpipe should be installed before installing indoor unit. After powering on, there is some water in water-receiver plate. Please check if the drain pump can operate correctly.
- ④ All connection should be firm.
- ⑤ Wipe color on PVC pipe to note connection.
- ⑥ Climbing, horizontal and bending conditions are prohibited.
- ⑦ The dimension of drainpipe can't less than the connecting dimension of indoor drainpipe.
- ⑧ Heat-insulation should be done well to prevent condensation.
- ⑨ Indoor units with different drainage type can't share one convergent drainpipe.

4.2 Drainpipe Trap

4.2.1. If the pressure at the connection of the drainpipe is negative, it needs to design drainpipe trap.

4.2.2. Every indoor unit needs one drainpipe trap.

4.2.3. A plug should be designed to do cleaning.

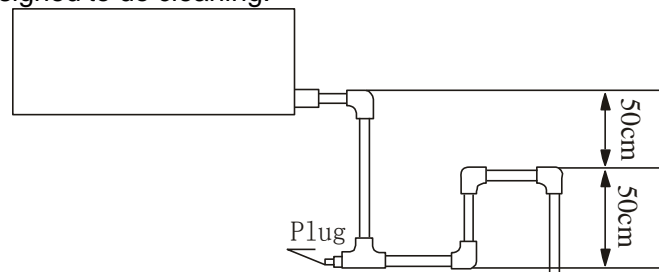

4.3 Upwards drainage (drain pump)

For Four-way cassette(compact)

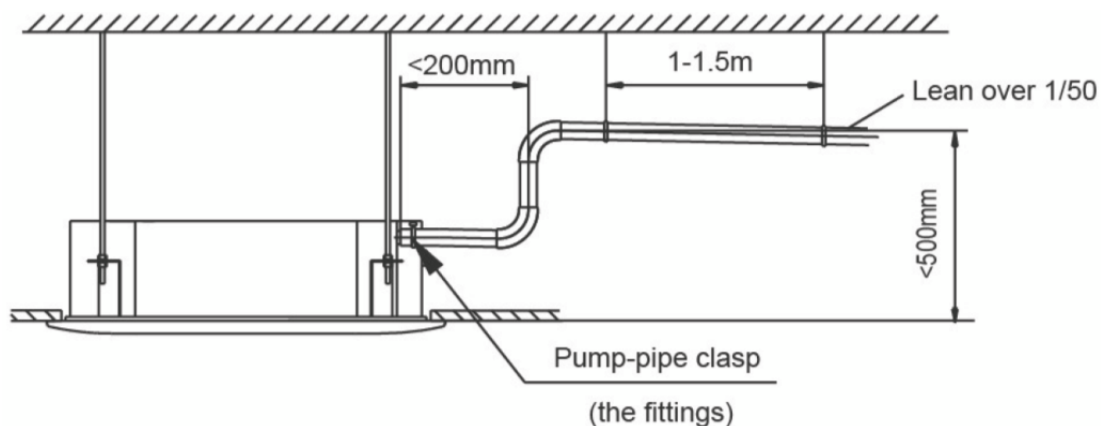

For Four-way cassette

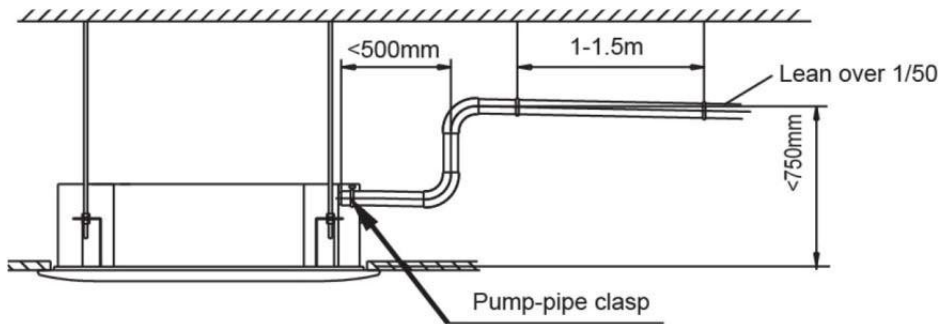

4.4 Convergent drainage

- 4.4.1. The number of indoor units should be as small as possible to prevent the traverse main pipe overlong.
- 4.4.2. Indoor unit with drain pump and indoor unit without drain pump should be in different drainage system.



4.4.3. Selecting the diameter

Number of connecting indoor units → Calculate drainage volume → Select the diameter
 Calculate allowed volume = Total cooling capacity of indoor units(HP) × 2 (l/ hr)

	Allowed volume(lean 1/50) (l/ hr)	I.D. (mm)	Thick
Hard PVC	~ ≤ 14	∅ 25	3.0
Hard PVC	14 < ~ ≤ 88	∅ 30	3.5
Hard PVC	88 < ~ ≤ 334	∅ 40	4.0
Hard PVC	175 < ~ ≤ 334	∅ 50	4.5
Hard PVC	334 < ~	∅ 80	6.0

4.5 Drainage test

4.5.1 Drainage without drain pump

After finishing drainpipe installation, pour some water into the water receiver plate to check if the water flows smoothly.

4.5.2 Drainage with drain pump

- ① Poke the Water Level Switch, remove the cover, use water pipe to pour 2000ml water into the water receipt plate through the water inlet.

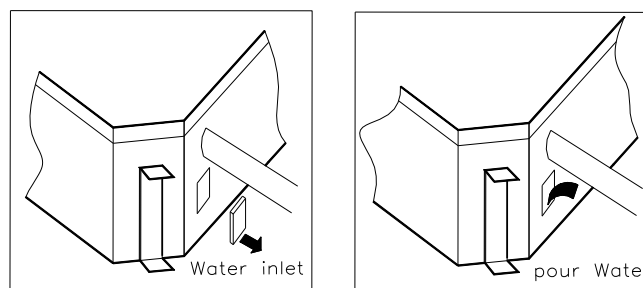

- ② Turn on the power to Cooling operation. Check the pump's operation and switch on the Water Level Switch. Check the pump's sound and look into the transparent hard pipe in the outlet at the same time to check if the water can discharge normally.

③ Stop the air conditioner running, turn off the power, and put back the cover.

- Stop the air conditioner. After 3 minutes, check if it has abnormality. If the collocation of drainpipes is illogical, the water will flow back overfull, which will cause the alarm lamp flashes, even overflow from the water receipt plate.
- Keep on pouring water until it gives an alarm signal for high water level, check if the pump drains water at once. If the water level can't fall below the alarmed water level after 3 minutes, the air conditioner will stop. Turn off the power and drain the remained water, and then turn on the air conditioner.

Note: the drain stuff in the main water receipt plate is for maintenance. Stuff up the drain stuff to prevent water leakage.

5. Insulation Work

5.1 Insulation material and thickness

5.1.1. Insulation material

Insulation material should adopt the material which is able to endure the pipe's temperature: no less than 70℃ in the high-pressure side, no less than 120℃ in the low-pressure side (For the cooling type machine, no requirements at the low-pressure side.)

- ◆ Example: Heat pump type----Heat-resistant Polyethylene foam (withstand above 120℃)
Cooling only type----Polyethylene foam (withstand above 100℃)

5.1.2. Thickness choice for insulation material

Insulation material thickness is as follows:

	Pipe diameter (mm)	Adiabatic material thickness
Refrigerant pipe	Φ6.4—Φ25.4	10mm
	Φ28.6—Φ38.1	15mm
Drainage pipe	Inner diameterΦ20—Φ32	6mm

5.2 Refrigerant pipe insulation

5.2.1. Work Procedure

- ① Before laying the pipes, the non-jointing parts and non-connection parts should be heat insulated.
- ② When the gas proof test is eligible, the jointing area, expanding area and the flange area should be heat insulated

5.2.2. Insulation for non-jointing parts and non-connection parts

wrong	right	
Gas pipe and liquid pipe should not be put together to insulate	Insulate the gas pipe (cooling only)	Insulate the gas pipe and liquid pipe

For construction convenience, before laying pipes, use insulation material to insulate the pipes to be deal with, at the same time, at two ends of the pipe, remain some length not to be insulated, in order to be welded and check the leakage after laying the pipes.

5.2.3. Insulate for the jointing area, expanding area and the flange area

- ① Insulate for the jointing area, expanding area and the flange area should be done after checking leakage of the pipes
- ② Make sure there's no clearance in the jointing part of the accessorial insulation material and local preparative insulation material.

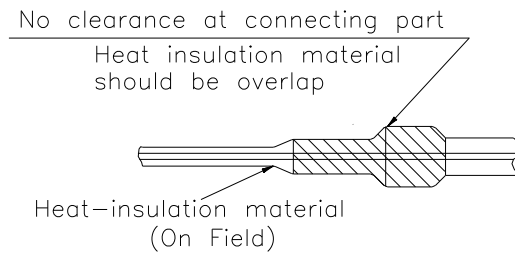

5.3 Drainage pipe insulation

The connection part should be insulated, or else water will be condensing at the non-insulation part.

5.4 Note

5.4.1 The jointing area, expanding area and the flange area should be heat insulated after passing the pressure test

5.4.2 The gas and liquid pipe should be heat insulated individually, the connecting part should be heat insulated individually.

5.4.3 Use the attached heat-insulation material to insulate the pipe connections (pipes' tie-in ,expand nut) of the indoor unit

6. Wiring

Please refer to the Wiring Diagram.

7. Test Operation

(1) The test operation must be carried out after the entire installation has been completed.

(2) Please confirm the following points before the test operation.

- The indoor unit and outdoor unit are installed properly.
- Tubing and wiring are correctly completed.
- The refrigerant pipe system is leakage-checked.
- The drainage is unimpeded.
- The ground wiring is connected correctly.
- The length of the tubing and the added stow capacity of the refrigerant have been recorded.
- The power voltage fits the rated voltage of the air conditioner.
- There is no obstacle at the outlet and inlet of the outdoor and indoor units.
- The gas-side and liquid-side stop valves are both opened.
- The air conditioner is pre-heated by turning on the power.

(3) According to the user's requirement, install the remote controller when the remote controller's signal can reach the indoor unit smoothly.

(4) Test operation

Set the air conditioner under the mode of "COOLING" with the remote controller, and check the following points.

Indoor unit

- Whether the switch on the remote controller works well.
- Whether the buttons on the remote controller works well.
- Whether the air flow louver moves normally.
- Whether the room temperature is adjusted well.
- Whether the indicator lights normally.
- Whether the temporary buttons works well.
- Whether the drainage is normal.
- Whether there is vibration or abnormal noise during operation.

Outdoor unit

- Whether there is vibration or abnormal noise during operation.
- Whether the generated wind, noise, or condensed of by the air conditioner have influenced your neighborhood.
- Whether any of the refrigerant is leaked.